



Zippie TS®

- with transit option without transit option

Supplier: This manual must be given to the rider of this wheelchair.

Rider: Before using this wheelchair read this entire manual and save it for future reference.

Owner's Manual

Zippie TS®

Distribuidor: Este manual debe ser entregado al pasajero de esta silla de ruedas.

Pasajero: Antes de usar esta silla de ruedas, lea este manual en su totalidad y guárdelo para futura referencia.

Cada una de las sillas se envía con un manual de instrucciones en inglés. El manual en español o francés está disponible en formato PDF en nuestra página en Internet: www.SunriseMedical.com. Ingrese a la página del producto específico para descargar el manual, o comuníquese con el proveedor autorizado de Sunrise Medical.

Manual de Instrucciones

Zippie TS®

Fournisseur: Ce manuel doit être remis à l'utilisateur / utilisatrice de ce fauteuil roulant.

Utilisateur / Utilisatrice: Avant d'utiliser ce fauteuil roulant, lisez entièrement ce manuel et conservez le pour le consulter ultérieurement.

Chaque fauteuil est livré avec un manuel d'instructions en anglais. Les versions en espagnol et en français sont à votre disposition en format PDF sur le site: www.SunriseMedical.com. Veuillez vous rendre à la page de votre produit pour télécharger le manuel dans la langue souhaitée, ou contactez un fournisseur agréé Sunrise Medical.

Mode d'emploi

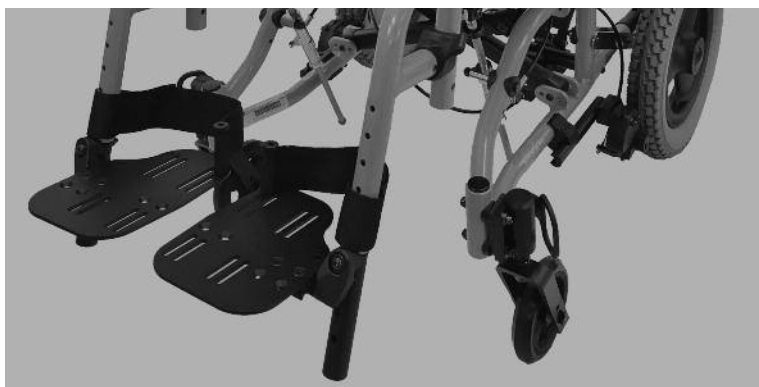

SUNRISE MEDICAL LISTENS

Thank you for choosing a Zippie wheelchair. We want to hear your questions or comments about this manual, the safety and reliability of your chair, and the service you receive from your Sunrise supplier. Please feel free to write or call us at the address and telephone number below:

Sunrise Medical (US) LLC
Customer Service Department
2842 Business Park Ave
Fresno, CA 93727
(800) 333-4000

Be sure to return your warranty card, and let us know if you change your address. This will allow us to keep you up to date with information about safety, new products and options to increase your use and enjoyment of this wheelchair. If you lose your warranty card, call or write and we will gladly send you a new one.

FOR ANSWERS TO YOUR QUESTIONS

Your authorized supplier knows your wheelchair best, and can answer most of your questions about chair safety, use and maintenance. For future reference, fill in the following:

Supplier: _____

Address: _____

Telephone: _____

Serial #: _____ Date/Purchased: _____

ADDITIONAL INFORMATION YOU SHOULD KNOW

No component of this chair was made with natural latex rubber

**DISPOSAL AND RECYCLING INFORMATION**

When this product reaches the end of its life, please take it to an approved collection or recycling point designated by your local or state government. This wheelchair is manufactured using a variety of materials. Your product should not be disposed of as ordinary household waste. You should dispose of your wheelchair properly, according to local laws and regulations. Most materials that are used in the construction of this product are fully recyclable. The separate collection and recycling of your product at the time of disposal will help conserve natural resources and ensure that it is disposed in a manner that protects the environment.

Ensure you are the legal owner of the product prior to arranging for the product disposal in accordance with the above recommendations.

I. INTRODUCTION	2	VIII. USE AND MAINTENANCE	14
II. TABLE OF CONTENTS.....	3	A. Introduction	14
III. YOUR CHAIR AND ITS PARTS.....	4	B. Critical Maintenance Tips.....	14
IV. NOTICE - READ BEFORE USE	4	C. Maintenance Chart	14
A. Choose the Right Chair & Safety Options	4	D. Cleaning Tips	14
B. Review This Manual Often	4	E. Troubleshooting Chart	14
C. Warnings	4	F. To Mount and Remove Rear Wheels.....	15
V. GENERAL WARNINGS	5	G. Wheel Locks	15
A. Weight Limit	5	H. Hub Locks	15
B. Intended Use	5	I. Anti-tips	16
C. Attendants and Caregivers	5	J. Single-Post Height Adjustable Armrest.....	16
D. Accessories	5	K. Z-FINITY Footrest system (Option)	17
E. Know Your Chair	5	L. Swing IN/OUT Hangers and Footrests	17
F. Reduce The Risk of an Accident	5	M. Heavy-duty Lift-off Footrests (Option)	17
G. Safety Checklist	5	N. Articulating/ Elevating Legrest (Option)	17
H. Changes & Adjustments	5	O. Folding and Unfolding	18
I. Environmental Conditions	6	P. Integrated Stroller Handles	18
J. Terrain	6	Q. Backrest	18
K. Street Use	6	R. Storage Tips.....	19
L. Motor Vehicle Safety	6	S. Check-Out	19
M. When You Need Help	6	IX. DEALER SERVICE AND ADJUSTMENT.....	20
VI. SAFETY WARNINGS: FALLS & TIP-OVERS.....	7	A. Dealer Service Introduction	20
A. Center of Balance	7	B. Critical Maintenance tips	20
B. Dressing or Changing Clothes	7	C. Cleaning	20
C. Obstacles	7	D. Rear Axles & Axle Plates.....	20
D. Front Caster Lift.....	7	E. Rear Wheel Axle Nut Adjustment.....	21
E. Reaching or Leaning.....	7	F. Wheel Locks	21
F. Moving Backward.....	7	G. Hub Locks	21
G. Escalators.....	8	H. Anti-tip Receivers	21
H. Ramps, Slopes & Sidehills	8	I. Armrest Receiver Attachment	22
I. Transfers	9	J. Flip-up Armrests.....	22
J. Curbs & Single Steps.....	9	K. Adjustable locking Flip-up armrest.....	22
K. Climbing a Curb or Single Step.....	10	L. T-post Armrest	22
L. Descending a Curb or Single Step	10	M. X-Finity™ Footrest System	23
M. Stairs	10	N. Articulating Legrest	23
N. Climbing Stairs	10	O. Elevating Legrest	23
O. Descending Stairs	10	P. Kids and Adult Angle Adjustable Footplates.....	24
VII. WARNINGS: COMPONENTS & OPTIONS	11	Q. Aluminum Footplate	24
A. Anti-Tip Tubes	11	R. 90° Footboard	24
B. Armrests	11	S. Caster forks	24
C. Cushion & Sling Seats	11	T. Caster Plates.....	25
D. Fasteners	11	U. Seat Depth	25
E. Footrests.....	11	V. Solid Back and Seat Insert	26
F. Pneumatic Tires	11	W. Tilt-in-Space.....	26
G. Positioning Belts Option	12	X. Cable Adjustment	27
H. Push Handles Option.....	12	Y. Cross-Brace	27
I. Quick-Release Axles	12	Z. Strut Tube Assembly	27
J. Rear Wheels	12	AA. Growing Seat Pan.....	28
K. Rear Wheel Locks	12	BB Check out.....	28
L. Modified Seat Systems	13	X. SUNRISE LIMITED WARRANTY	32
M. Seat and Back Upholstery	13		
N. Power Drive.....	13		
O. Dynamic Backrest.....	13		
P. Anti-tip Receivers	13		

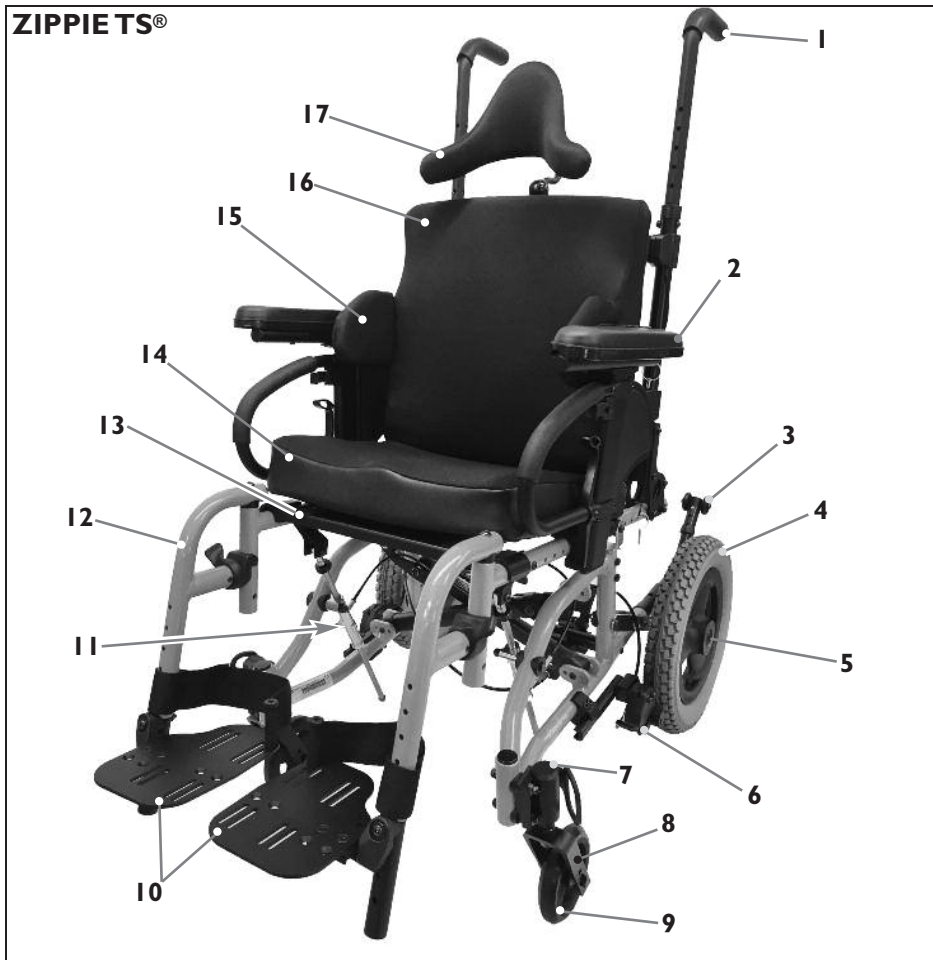

1. Push handle
2. Single Post Height adjustable armrest
3. Anti-tip Tube
4. Rear Tire 12"
5. Quick-Release Axle
6. Foot lock (Option)
7. Caster Barrel
8. Caster fork
9. Caster wheel
10. Adjustable Foot plates (Option)
11. Strut Tube (Tilt)
12. Swing in / out hangers
13. Seat pan
14. Cushion
15. Lateral (Option)
16. Solid Back
17. Headrest (Option)

Note: All features may not be available with some chair setups or in conjunction with another chair feature. Please consult your authorized dealer for more information.

IV. NOTICE- READ BEFORE USE

A. CHOOSE THE RIGHT CHAIR & SAFETY OPTIONS

Sunrise provides a choice of many wheelchair styles to meet your needs. This product is intended for single person use only. Final selection of the type of wheelchair, options and adjustments rests solely with you and your health care professional. Choosing the best chair for your unique mobility needs, will depend on such things as:

1. Your disability, strength, balance and coordination.
2. The types of hazards you must overcome in daily use (where you live and work, and other places you are likely to use your chair).
3. The need for options that will improve your positioning, safety and comfort (such as anti-tip tubes, positioning belts, or special seating systems).

B. REVIEW THIS MANUAL OFTEN

Before using this chair you, and each person who may assist you, should read this entire manual and make sure to follow all instructions. Review the warnings often, until they are second nature to you.

C. WARNINGS 

The word "WARNING" refers to a hazard or unsafe practice that may cause severe injury or death to you or to other persons. The "Warnings" are in three main sections, as follows:

1. V — GENERAL WARNINGS

Here you will find a safety checklist and a summary of risks you need to be aware of before you ride this chair.

2. VI— SAFETY WARNINGS: FALLS & TIP-OVERS

Here you will learn about practices for the safe use of your chair, and how to avoid a fall or tip-over while you perform daily activities in your chair.

3. VII — WARNINGS — COMPONENTS & OPTIONS

Here you will learn about the components of your chair and options you can select for safety. Consult your authorized supplier and your health care advisor to help you choose the best set-up and options for safe use.

NOTE— Where they apply, you will also find "Warnings" in other sections of this manual. Heed all warnings in these sections. If you fail to do so a fall, tip-over or loss of control may occur and cause severe injury to the rider or others.

A. WEIGHT LIMIT.**⚠ WARNING**

NEVER exceed the weight limit specified by Sunrise Medical. The weight capacity provided by your manufacturer is for the combined weight of a rider and items carried using on-board storage. If you do exceed the weight limit, damage to your chair, a fall, tip-over or loss of control may occur and cause severe injury to the rider or others.

Weight Capacity

Zippie TS® - 165lbs/(75kg).

B. INTENDED USE

The Zippie TS® wheelchair's intended use is to provide mobility to children limited to a sitting position.

⚠ WARNING

DO NOT use this device for purposes other than what is intended by the manufacturer

1. The wheelchair is not designed for weight training and is unsafe for use as a seat while weight training. Weight training from the wheelchair substantially changes the stability of the chair and may cause tipping.
2. DO NOT stand on the frame of the wheelchair.
3. NEVER allow someone to stand on your chair or use it as a step ladder.
4. This chair is designed for a single rider only.
5. Unauthorized modifications and use of parts or accessories not supplied or approved by Sunrise Medical may change the chair structure. This will void the warranty and may cause a safety hazard. If the warning is ignored, damage to your chair, and the potential severe injury of the person using the chair for unintended purposes can occur.

C. ATTENDANTS AND CAREGIVERS**⚠ WARNING**

Before you assist a rider, be sure to read all warnings contained in this manual, and follow all instructions that apply. Be aware that after consulting a healthcare advisor, you will need to learn safe and proven body mechanics to use and create assistive methods best suited to your abilities.

D. ACCESSORIES**⚠ WARNING**

Unauthorized modifications or use of parts, or accessories not supplied or approved by Sunrise Medical may change the chair structure. This will void the warranty and may cause a safety hazard.

Some problems that may occur, but are not limited to:

1. Incorrect Wheels and/or tires that put the rider at risk of a fall or tip-over.
2. Adding a component to the frame, changing the structural integrity of the chair.
3. Any modification or disassembly can potentially create an unsafe situation where rider and/or attendant are put at risk.

E. KNOW YOUR CHAIR**⚠ WARNING**

Every wheelchair is different. Take the time to learn the feel of this chair before you begin riding. Start slowly, with easy, smooth strokes. If you are used to a different chair, you may use too much force and tip over. If you use too much force, damage to your chair, a fall, tip-over or loss of control may occur and cause severe injury to the rider or others.

F. REDUCE THE RISK OF AN ACCIDENT**⚠ WARNING**

1. BEFORE you begin riding, you should be trained in the safe use of this chair by your health care advisor.
2. Practice bending, reaching and transfers until you know the limit of your ability. Have someone help you until you know what can cause a fall or tip-over and how to avoid doing so.
3. Be aware that you must develop your own methods for safe use best suited to your level of function and ability.
4. NEVER try a new maneuver on your own. Ask the advice of your health care provider to lower the risk of a fall or tip over.
5. Get to know the areas where you plan to use your chair. Look for hazards and learn how to avoid them.

G. SAFETY CHECKLIST**⚠ WARNING**

Before Each Use Of Your Chair:

1. Make sure the chair rolls easily and that all parts work smoothly. Check for noise, vibration, or a change in ease of use. (This may indicate low tire pressure, loose fasteners, or damage to your chair).
2. Inspect any problem. Your authorized supplier can help you find and correct the problem.
3. Check to see that both quick-release rear axles are locked. When locked, the axle button will "pop out" fully. If not locked, the wheel may come off and cause you to fall.
4. If your chair has anti-tip tubes, lock them in place.

H. CHANGES & ADJUSTMENTS**⚠ WARNING**

1. See your healthcare advisor and have them adjust seating components any time a change or adjustment needs to be made.
2. Unauthorized modifications or use of parts not supplied or approved by Sunrise may change the chair structure. This will void the warranty and may cause a safety hazard.

If you fail to heed these warnings damage to your chair, a fall, tip-over or loss of control may occur and cause severe injury to the rider or others.

I. ENVIRONMENTAL CONDITIONS

⚠ WARNING



1. Use extra care if you must ride your chair on a wet or slick surface. If you are in doubt, ask for help.
2. Contact with water or excess moisture may cause your chair to rust or corrode. Avoid all extreme weather situations if possible.
 - a. Do not use your chair in a shower, pool or other body of water. The chair tubing and parts are not water-tight and may rust or corrode from the inside.
 - b. Avoid excess moisture (for example, do not leave your chair in a damp bathroom while taking a shower).
 - c. Dry your chair as soon as you can if it gets wet, or if you use water to clean it.

If you fail to heed these warnings damage to your chair, a fall, tip-over or loss of control may occur and cause severe injury to the rider or others.

J. TERRAIN

⚠ WARNING

1. Based on ANSI/RESNA testing, Sunrise Medical recommends the use of a caster wheel with a minimum diameter of 5", if the wheelchair will be overcoming obstacles up to 1/2" on a regular basis.
2. Your chair is designed for use on firm, even surfaces such as concrete, asphalt, indoor flooring, and carpets.
3. Do not operate your chair in sand, loose soil, or over rocky terrain.
4. If you use your chair on terrain that is rougher than described above there is a danger that screws and bolts will loosen prematurely, and that damage to wheels or axles could put the rider at risk of a fall, tip-over, or loss of control.

If you fail to heed these warnings damage to your chair, a fall, tip-over or loss of control may occur and cause severe injury to the rider or others.

K. STREET USE

⚠ WARNING

1. This product is not intended for street use.
2. Avoid streets whenever possible.
3. Obey and follow all legal pedestrian pathways, and laws that apply to pedestrians.
4. Be alert to the danger of motor vehicles in parking lots, or if you must cross a road.

If you fail to heed this warning, damage to your chair, and a possible collision may occur and cause severe injury to the rider or others.

L. MOTOR VEHICLE SAFETY 1 2

If possible and feasible, the rider should transfer to the Original Equipment Manufacturer vehicle seat and use the OEM vehicle restraint.

Sunrise Medical does provide a WC-19 Wheelchair Tie-Down and Occupant Restraint System, otherwise called a Transit Option. To Identify whether your wheelchair has been manufactured with the Transit Option installed, look for four points of securement. Two Front points (A), and two rear points (B). These points are recognized by the securement point decal which can be found on or near the securement points.

If your wheelchair is equipped with the Transit Option, please review the Transit Securement supplement that was provided with the wheelchair for additional information and instructions. You can request a copy from your authorized supplier, or call Sunrise medical at 1-800-333-4000 if you don't have it.

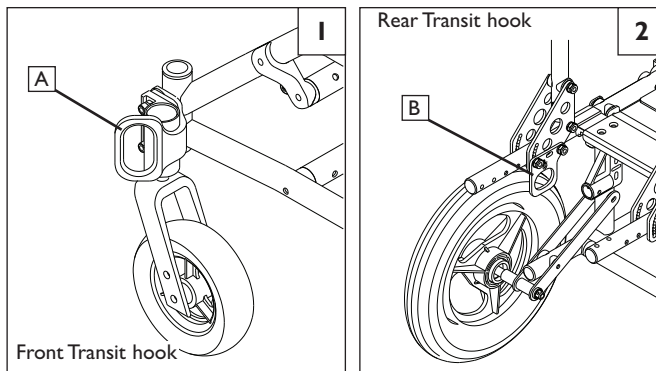

Look for this symbol on your wheelchair. It indicates wheelchair securement points which conform to ANSI/RESNA (1998) V.1 - Section 19 and/or ANSI/RESNA (2012) V.4 WC-19. For more Transit related information, see the "Transit Securement Supplement" included with your chair.

⚠ WARNING

If your chair is **NOT** equipped with the Transit Option:

1. NEVER let anyone sit in this chair while in a moving vehicle.
 - a. ALWAYS move the rider to an approved vehicle seat.
 - b. ALWAYS secure the rider with proper motor vehicle restraints.
2. In an accident or sudden stop the rider may be thrown from the chair. Wheelchair seat belts will not prevent this, and further injury may result from the belts or straps.
3. NEVER transport this chair in the front seat of a vehicle. It may shift and interfere with the driver.
4. ALWAYS secure this chair so that it cannot roll or shift.
5. Do not use any chair that has been involved in a motor vehicle accident. The frame and/or components may have been changed due to the accident. Such items could be, but are not limited to: bent, loosened, and/or broken components that were subjected to an impact.

Failure to heed these warnings puts you and others that may assist you at a high risk of injury.

M. WHEN YOU NEED HELP

⚠ WARNING

For The Rider: Make sure that each person who helps you reads and follows all warnings and instructions that apply.

For Attendants:

1. Work with the rider's doctor, nurse or therapist to learn safe methods best suited to your abilities and those of the rider.
2. Tell the rider what you plan to do, and explain what you expect the rider to do. This will put the rider at ease and reduce the risk of an accident.
3. Make sure the chair has push handles. They provide secure points for you to hold the rear of the chair to prevent a fall or tip-over. Check to make sure push handle grips will not rotate or slip off.
4. To prevent injury to your back, use good posture and proper body mechanics. When you lift or support the rider or tilt the chair, bend your knees slightly and keep your back as upright and straight as you can.
5. Remind the rider to lean back when you tilt the chair backward.
6. When you descend a curb or single step, slowly lower the chair in one easy movement. Do not let the chair drop the last few inches to the ground. This may damage the chair or injure the rider.
7. To avoid tripping, unlock and rotate anti-tip tubes up, out of the way.
8. Whenever you aren't attending the wheelchair, ALWAYS use the wheel-lock to secure the rear wheels, and lock the anti-tip tubes in place.

If you fail to ask for help when in doubt, you run a high risk of a fall, tip-over or loss of control that may occur and cause severe injury to the rider or others.

A. CENTER OF BALANCE**⚠ WARNING**

The point where this chair will tip forward, back or to the side depends on its center of balance and stability. How your chair is set up, the options you select and the changes you make may affect the risk of a fall or tip-over.

1. **The Most Important Adjustment Is:**
The position of the rear wheels. The more you move the rear wheels forward, the more likely your chair will tip over backward.
2. **The Center Of Balance Is Also Affected By:**
 - a. A change in the set-up of your chair, including:
 - The distance between the rear wheels.
 - The amount of rear wheel camber.
 - The seat height and seat angle.
 - Backrest angle.
 - b. A change in your body position, posture or weight distribution.
 - c. Riding your chair on a ramp or slope.
 - d. A back pack or other options and the amount of added weight.
3. **To Reduce The Risk Of An Accident:**
 - a. Consult your doctor, nurse or therapist to find out what axle and caster position is best for you.
 - b. Consult your authorized supplier **BEFORE** you modify or adjust this chair. Be aware that you may need to make other changes to correct the center of balance.
 - c. Have someone help you until you know the balance points of your chair and how to avoid a tip-over.
 - d. Use anti-tip tubes.

If you fail to heed these warnings, you are at a high risk of a fall, tip-over or loss of control that could cause severe injury to the rider or others.

B. DRESSING OR CHANGING CLOTHES**⚠ WARNING**

Your weight may shift if you dress or change clothes while seated in this chair.

To reduce the risk of a fall or tip-over:

1. Rotate the front casters until they are as far forward as possible.
This makes the chair more stable.
2. Lock anti-tip tubes in place. (If your chair does not have anti-tip tubes, back it up against a wall and lock both rear wheels).

If you fail to heed this warning, damage to your chair, a fall, tip-over or loss of control may occur and cause severe injury to the rider or others.

C. OBSTACLES**⚠ WARNING**

Riding over curbs or obstacles can cause tipping and serious bodily harm. If you have any doubt that you can safely cross any curb or obstacle, **ALWAYS ASK FOR HELP**. Be aware of your riding skills and personal limitations. Develop new skills only with the help of a companion.

To avoid the risk of traversing obstacles:

1. Keep a lookout for danger – scan the area well ahead of your chair as you ride.
2. Make sure the floor areas where you live and work are level and free of obstructions.
3. Remove or cover threshold strips between rooms.
4. Install a ramp at entry or exit doors. Make sure there is not a drop off at the bottom of the ramp.
5. **To Help Correct Your Center Of Balance:**
 - a. Lean your upper body **FORWARD** slightly as you go **UP** over an obstacle.
 - b. Press your upper body **BACKWARD** as you go **DOWN** from a higher to a lower level.

6. If your chair has anti-tip tubes, do not go over an obstacle without help.
7. Keep both of your hands on the handrims as you go over an obstacle.
8. Never push or pull on an object (such as furniture or a doorjamb) to propel your chair.

If you fail to heed these warnings damage to your chair, a fall, tip-over or loss of control may occur and cause severe injury to the rider or others.

D. FRONT CASTER LIFT**⚠ WARNING**

Front caster lift can occur when the front wheels, ordinarily in contact with the ground, are either intentionally, or unintentionally caused to lift from the ground while the rear wheels remain in contact. Pitch control (partial or full) should **NEVER** be attempted without consulting your healthcare advisor and making sure that anti-tips are installed.

If you fail to heed this warning, you are at a high risk of damage to your chair, a fall, tip-over or loss of control that may occur and cause severe injury to the rider or others.

E. REACHING OR LEANING**⚠ WARNING**

If you reach or lean it will affect the center of balance of your chair. This may cause you to fall or tip over. When in doubt, ask for help or use a device to extend your reach.

1. **NEVER** reach or lean if you must shift your weight sideways or rise up off the seat.
2. **NEVER** reach or lean if you must move forward in your seat to do so. Always keep your buttocks in contact with the backrest.
3. **NEVER** reach with both hands (you may not be able to catch yourself to prevent a fall if the chair tips).
4. **NEVER** reach or lean to the rear unless your chair has anti-tip tubes locked in place.
5. **DO NOT** reach or lean over the top of the seat back. This may damage one or both backrest tubes and cause you to fall.
6. **If You Must Reach Or Lean:**
 - a. Do not lock the rear wheels. This creates a tip point and makes a fall or tip-over more likely.
 - b. Do not put pressure on the footrests.
 - c. Move your chair as close as you can to the object you wish to reach.
 - d. Do not try to pick up an object from the floor by reaching down between your knees. You are less likely to tip if you reach to the side of your chair.
 - e. Rotate the front casters until they are as far forward as possible. This makes the chair more stable.
 - f. Firmly grasp a rear wheel or an armrest with one hand. This will help to prevent a fall if the chair tips.

If you fail to heed these warnings damage to your chair, a fall, tip-over or loss of control may occur and cause severe injury to the rider or others.

F. MOVING BACKWARD**⚠ WARNING**

Use extra care when you move your chair backward. Your chair is most stable when you propel yourself forward. You may lose control or tip over if one of the rear wheels hits an object and stops rolling.

1. Propel your chair slowly and smoothly.
2. If your chair has anti-tip tubes, make sure to lock them in place.
3. Stop often and check to be sure your path is clear.

If you fail to heed this warning, you are at a high risk of damage to your chair, a fall, tip-over or loss of control that may occur and cause severe injury to the rider or others.

G. ESCALATORS**⚠ WARNING**

NEVER use this chair on an escalator, even with an attendant. If you do, a fall or tip-over is likely. If you fail to heed this warning you and others that may be assisting you, are at a high risk of severe injury.

H. RAMPS, SLOPES & SIDEHILLS 3 4 5 6**⚠ WARNING**

Whenever possible, avoid riding on a slope, which includes a ramp or sidehill. This will change the center of balance of your chair. Your chair is less stable and more difficult to maneuver when it is at an angle. When moving up a hill, anti-tip tubes may not prevent a fall or tip-over.

1. **DO NOT** use your chair on a slope steeper than 10%. (A 10% slope means: one foot in elevation for every ten feet of slope length.)
2. **ALWAYS** go as straight up and as straight down as you can. (Do not “cut the corner” on a slope or ramp.)
3. **DO NOT** turn or change direction on a slope.
4. When you have to use a ramp, always stay in the CENTER of the ramp. Make sure ramp is wide enough that you have no risk of going off the edge.
5. **DO NOT** stop on a steep slope. If you stop, you may lose control of your chair.
6. **NEVER** use rear wheel locks to try to slow or stop your chair. This is likely to cause your chair to veer out of control.
7. **ALWAYS** be aware of:
 - a. Wet or slippery surfaces.
 - b. A change in grade on a slope (or a lip, bump or depression). These may cause a fall or tip-over.
 - c. A drop-off at the bottom of a slope or ramp. A drop-off as small as 3/4 inch can stop a front caster and cause the chair to tip forward.
8. To Reduce The Risk Of A Fall Or Tip-Over:
 - a. Lean or press your body UPHILL. This will help adjust for the change in the center of balance caused by the slope or sidehill.
 - b. Keep pressure on the handrims to control your speed on a down slope. If you go too fast you may lose control.
 - c. **ASK FOR HELP** any time you are in doubt.
9. Ramps At Home & Work– For your safety, ramps at home and work must meet all legal requirements for your area:
 - a. **AVOID A DROP-OFF**
Make sure there is a section at the top or bottom to smooth out the transition.
 - b. **ALWAYS** stay in the center of the ramp and control your speed.

If you fail to heed these warnings damage to your chair, a fall, tip-over or loss of control may occur and can possibly cause severe injury to the rider or others.

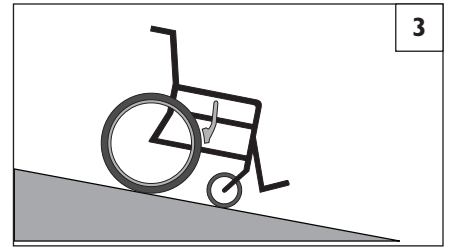

- IF** you need to go down a hill:
- a. The Downslope should be less than 6°.
 - b. **GO SLOW** Control your speed.
 - c. **ALWAYS** Go Straight down.
 - d. Never turn on a hill.
 - e. **ALWAYS** lean backward.

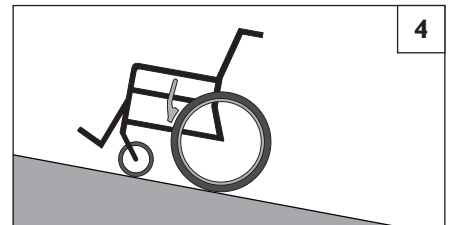

- IF** you need to go up a hill:
- a. The Upslope should be less than 6°.
 - b. **ALWAYS** Go Straight up.
 - c. **DON'T STOP**.
 - d. **NEVER** turn on a hill.
 - e. **ALWAYS** lean forward.

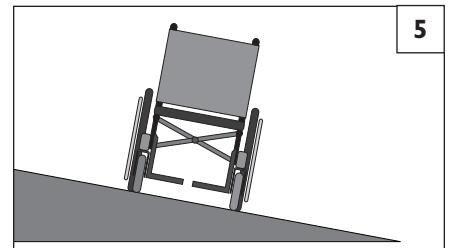

- IF** you need to traverse a Sidehill:
- a. The sidehill must be Less than 6° or you are at risk of a tip over.
 - b. **DON'T STOP**.
 - c. **NEVER** turn on a hill.

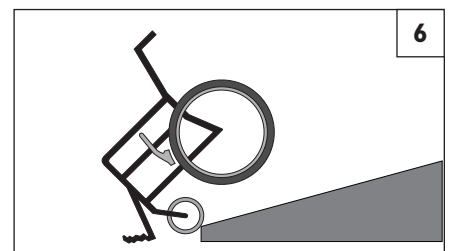

- If** you need to traverse a Ramp:
- a. Go Slowly.
 - b. **Watch out for Drop-offs.**
 - c. **ALWAYS** go straight up or straight down.
 - d. Stay centered on the Ramp.

I. TRANSFERS 7 8

⚠ WARNING

It is dangerous to transfer on your own. It requires good balance and agility. Be aware that there is a point during every transfer when the wheelchair seat is not below you. To avoid a fall:

1. Work with your health care advisor to learn safe methods for transfers.
 - a. Learn how to position your body and how to support yourself during a transfer.
 - b. Have someone help you until you learn safe transfer methods.
2. Lock the rear wheels before you transfer.
3. Be aware that the chair can still slide and/or tip. The wheel lock keeps the rear wheels from rolling while you are performing the transfer.
4. Make sure that the pneumatic tires are properly inflated. Low tire pressure may allow the rear wheel locks to slip. (see table in Section G “Pneumatic Tires”)
5. Move your chair as close as you can to the seat you are transferring to. If possible, use a transfer board.
6. Rotate the front casters until they are as far forward as possible.
7. If you can, remove the footrests, or swing them out of the way.
 - a. Make sure your feet do not catch in the space between the footrests.
 - b. Avoid putting weight on the footrests as this may cause the chair to tip.
8. Make sure armrests are removed, or out of the way and do not interfere with the transfer.
9. Transfer as far back onto the seat surface as you can. This will reduce the risk that the chair will tip or move away from you.

Optimum Transfer position



- Before transferring:
1. Remove the armrests.
 2. Remove or move the footrests.
 3. Make sure the wheel lock is set.

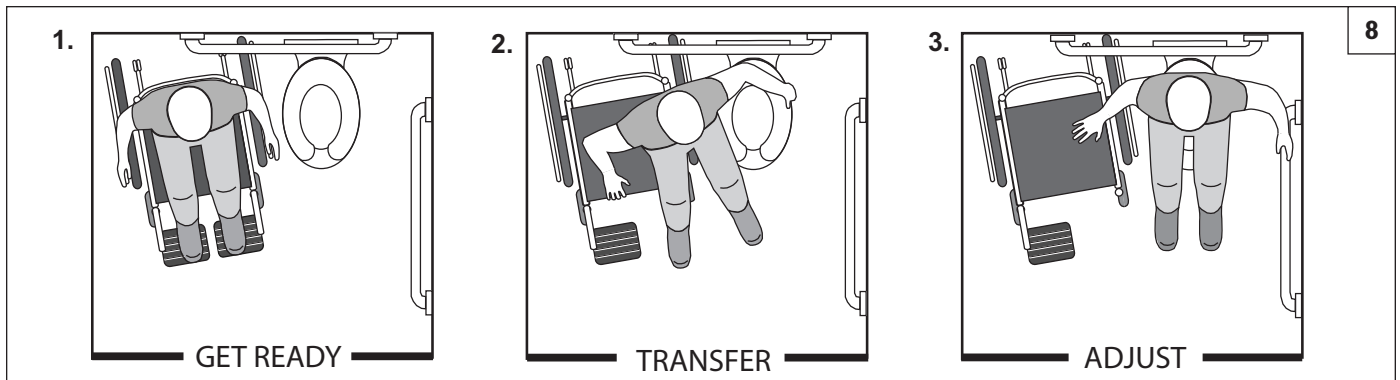

J. CURBS & SINGLE STEPS 9

⚠ WARNING

Before riding over curbs, and negotiating even a single step, ALWAYS ask for assistance first. Curbs and steps can cause tipping and serious bodily harm. When in doubt as to your ability to avoid, or traverse any obstacle, always ask for help. Be aware of your riding skills and personal limitations. Develop new skills only with the help of a companion.

For Attendant: Each person who assists the rider with curbs and steps should read and follow all instructions and warnings pertaining to attendants, and caregivers.

1. Do not try to climb a high curb or step (more than 4 inches high) UNLESS you have help. Doing so may cause your chair to exceed its balance point and tip over.
2. Go straight up and straight down a curb or step. If you climb or descend at an angle, a fall or tip-over is likely.
3. Be aware that the impact of dropping down from a curb or step can damage your chair or loosen fasteners.

If you fail to heed these warnings damage to your chair, a fall, tip-over or loss of control may occur and can possibly cause severe injury to the rider or others.

K. CLIMBING A CURB OR SINGLE STEP 9**⚠ WARNING**

For Attendant: follow these steps to help the rider climb a curb or single step going **BACKWARD**:

1. Stay behind the chair.
2. Continue backward until the rear wheels contact the face of the curb or step. Lift and roll the rear wheels to the top of the curb.
3. Pull the chair backwards until the caster wheels have cleared the edge of the curb and return the chair to it's rolling position.

If you fail to heed these warnings damage to your chair, a fall, tip-over or loss of control may occur and cause severe injury to the rider or others.

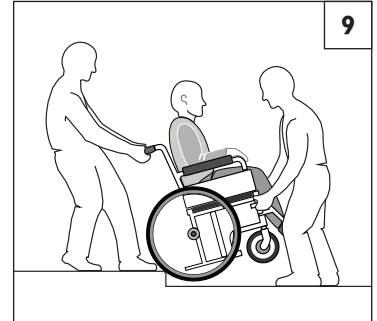
**L. DESCENDING A CURB OR SINGLE STEP** 9**⚠ WARNING**

For Attendant:: Follow these steps to help a rider descend a curb or single step going **FORWARD**:

1. Stay at the rear of the chair.
2. Several feet before you reach the edge of the curb or step, tip the chair slightly and pull it backward.
3. When the chair is at it's balance point, carefully step forwards until the rear wheels reach the edge of the curb or step. Then allow the rear wheels to slowly roll down onto the lower level.
4. Push the chair forward until you are standing on the lower level.
5. When the rear wheels are safely on the lower level, tilt the chair back to its balance point.

If you fail to heed these warnings damage to your chair, a fall, tip-over or loss of control may occur and cause severe injury to the rider or others.

M. STAIRS 10**⚠ WARNING**

1. NEVER use this chair on stairs UNLESS you have someone to help you. Doing so is likely to cause a fall or tip-over.
2. Negotiating stairs with a wheelchair always requires at least 2 attendants for safety.

If you fail to heed these warnings damage to your chair, a fall, tip-over or loss of control may occur and cause severe injury to the rider or others.

N. CLIMBING STAIRS 10**⚠ WARNING**

1. Use at least two attendants to move a chair and rider up stairs.
2. Move the chair and rider **BACKWARD** up the stairs.
3. The person at the rear is in control. He or she tilts the chair back to its balance point.
4. A second attendant at the front firmly grasps a non-detachable part of the front frame and lifts the chair up and over one stair at a time.
5. The attendants move to the next stair up. Repeat for each stair, until you reach the landing.

If you fail to heed these warnings damage to your chair, a fall, tip-over or loss of control may occur and cause severe injury to the rider or others.

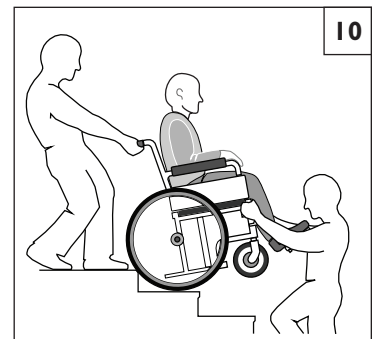
**O. DESCENDING STAIRS** 10**⚠ WARNING**

1. Use at least two attendants to move a chair and rider down stairs.
2. Move the chair and rider **FORWARD** down the stairs.
3. The person at the rear is in control. He or she tilts the chair to the balance point of the rear wheels and rolls it to the edge of the top step.
4. A second attendant stands on the third step from the top and grasps the chair frame. He or she lowers the chair one step at a time by letting the rear wheels roll over the stair edge.
5. The attendants move to the next stair down. Repeat for each stair, until you reach the landing.

If you fail to heed these warnings damage to your chair, a fall, tip-over or loss of control may occur and cause severe injury to the rider or others.

A. ANTI-TIPTUBES



Anti-tip tubes can help keep your chair from tipping over backward in normal conditions.

1. Sunrise recommends the use of anti-tip tubes:
2. When locked in place (in the “down” position) anti-tip tubes should be BETWEEN 1 1/2 to 2 inches off the ground.
 - a. If set **higher** than 2 inches, they may not prevent a tip-over.
 - b. If set **lower** than 2 inches, they may “hang up” on obstacles and cause a fall or tip over.
3. If you have to climb or descend a curb, or overcome an obstacle it may be necessary to have an attendant make sure the anti-tip tubes are rotated up, and out of the way, so that the chair and rider do not get stuck and/or become unstable.

If you fail to heed these warnings damage to your chair, a fall, tip-over or loss of control may occur and cause severe injury to the rider or others.

B. ARMRESTS



Armrests detach and will not bear the weight of this chair.

1. NEVER lift this chair by its armrests. They may come loose or break.
2. Lift this chair only by non-detachable parts of the main frame.

If you fail to heed these warnings damage to your chair, a fall, tip-over or loss of control may occur and cause severe injury to the rider or others.

C. CUSHIONS & SLING SEATS



1. Zippie sling seats and standard foam cushions are not designed for the relief of pressure.
2. If you suffer from pressure sores or if you are at risk that they will occur, you may need a special seat system or a device to control your posture. Consult your doctor, nurse or therapist to find out if you need such a device for your well-being.
3. Seat slings are not intended to be used as a direct seating surface. A cushion or other seating surface should be placed on the sling before use.

If you fail to heed these warnings damage to your chair, a fall, tip-over or loss of control may occur and cause severe injury to the rider or others.

D. FASTENERS



Many of the screws, bolts and nuts on this chair are special high-strength fasteners. Use of improper fasteners may cause your chair to fail.

1. ONLY use fasteners provided by an authorized supplier (or ones of the same type and strength, as indicated by the markings on the heads).
2. Over- or under-tightened fasteners may fail or cause damage to chair parts.
3. If bolts or screws become loose, tighten them as soon as you can.

If you fail to heed these warnings damage to your chair, a fall, tip-over or loss of control may occur and cause severe injury to the rider or others.

E. FOOTRESTS



1. At the lowest point, footrests should be AT LEAST 2 inches off the ground. If set too LOW, they may “hang up” on obstacles you can expect to find in normal use. This may cause the chair to stop suddenly and tip forward.
2. To Avoid A Trip Or Fall When You Transfer:
 - a. Make sure your feet do not “hang up” or get caught in the space between the footrests.
 - b. Avoid putting weight on the footrests, as the chair may tip forward.
 - c. Footrests should be swung out of the way or removed whenever entering or exiting the wheelchair.
3. NEVER lift this chair by the footrests. Footrests detach and will not bear the weight of this chair. Lift this chair only by non-detachable parts of the main frame.
4. Never use the footrests of the chair to open doors, this may cause them to fail prematurely, and create an unsafe situation.

If you fail to heed these warnings damage to your chair, a fall, tip-over or loss of control may occur and cause severe injury to the rider or others.

F. PNEUMATIC TIRES



Proper inflation extends the life of your tires and makes your chair easier to use.

1. Do not use this chair if any of the tires are under- or over-inflated. Check weekly for proper inflation level, as listed on the tire sidewall.
2. Low pressure in a rear tire may cause the wheel lock on that side to slip and allow the wheel to turn when you do not expect it.
3. Low pressure in any of the tires may cause the chair to veer to one side and result in a loss of control.
4. Over-inflated tires may burst.

If you fail to heed these warnings damage to your chair, a fall, tip-over or loss of control may occur and cause severe injury to the rider or others.

Tires	Zippie TS	Recommended Pressure or Pressure Range	
		kPa	PSI
Pneumatic - 12"	x	270	40
Pneumatic - 16"	x	240	35
Pneumatic - 20"	x	448	65
Pneumatic - 22"	x	448	65
Pneumatic - 24"	x	517	75
High Pressure Clincher (24")	x	758	110

G. POSITIONING BELTS (OPTIONAL)**⚠ WARNING**

The positioning belt is predominately used to support your posture. It can also be used to limit slipping and/or sliding that you might experience when the chair is in motion. The positioning belt is not a transit rated safety belt and should not be used in the place of a seat belt while being transported in a motor vehicle. Improper use of Positioning belts may cause severe injury or death. If you use a positioning belt, be sure to follow the recommendations in this section:

1. Make sure the rider does not slide down in the wheelchair seat. If this occurs, the rider may suffer chest compression or suffocate due to pressure from the belts.
2. The belts must be snug, but must not be so tight that they interfere with breathing. You should be able to slide your open hand, flat, between the belt and the rider.
3. A pelvic wedge or a similar device can help keep the rider from sliding down in the seat. Consult with the rider's doctor, nurse or therapist to find out if the rider needs such a device.
4. Use positioning belts only with a rider who can cooperate. Make sure the rider can easily remove the belts in an emergency.
5. NEVER use positioning belts
 - a. As a patient restraint. A restraint requires a doctor's order.
 - b. On a rider who is comatose or agitated.
 - c. As a motor vehicle restraint. In an accident or sudden stop the rider may be thrown from the chair. Wheelchair seat belts will not prevent this, and further injury may result from the belts or straps.

If you fail to heed these warnings damage to your chair, a fall, tip-over or loss of control may occur and cause severe injury to the rider or others.

H. PUSH HANDLES (OPTIONAL) II**⚠ WARNING**

When you have an attendant, make sure that this chair has push handles or stroller handles (A).

1. Push handles provide secure points for an attendant to hold the rear of this chair, to prevent a fall or tip-over.
2. Check to make sure push handle grips will not rotate or slip off.

If you fail to heed these warnings damage to your chair, a fall, tip-over or loss of control may occur and cause severe injury to the rider or others.

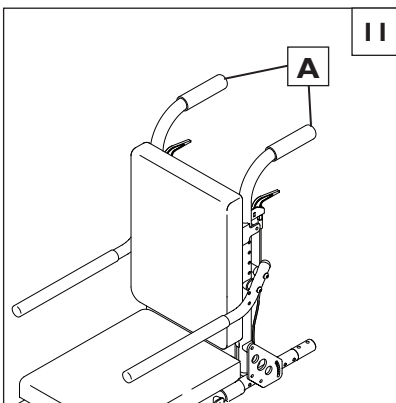
**I. QUICK-RELEASE AXLES****⚠ WARNING**

1. Do not use this chair UNLESS you are sure that both quick-release rear axles are locked.
 2. An axle is not locked until the quick-release button pops out fully.
 3. An unlocked axle may come off during use, resulting in a fall, tip-over or loss of control and cause severe injury to the rider or others.
 - Quick-Release Axles should be periodically cleaned and inspected for function and signs of wear or bending. Replace as necessary.

If you fail to heed these warnings damage to your chair, a fall, tip-over or loss of control may occur and cause severe injury to the rider or others.

J. REAR WHEELS**⚠ WARNING**

A change in set-up of the rear wheels will affect the center of balance of your chair.

1. The farther you move the rear axles FORWARD, the more likely it is that your chair will tip over backward.
2. Consult your healthcare advisor to find the best rear axle set-up for your chair. Do not change the set-up UNLESS you consult your healthcare advisor first.
3. Adjust the rear wheel locks after you make any change to the rear axles.
 - a. If you fail to do so, the wheel locks may not work.
 - b. Make sure lock arms embed in the tires at least 1/8 inch when locked.

If you fail to heed these warnings damage to your chair, a fall, tip-over or loss of control may occur and cause severe injury to the rider or others.

K. REAR WHEEL LOCKS**⚠ WARNING**

Rear wheel locks are NOT designed to slow or stop a moving wheelchair. Use them only to keep the rear wheels from rolling when your chair is at a complete stop.

1. NEVER use rear wheel locks to try to slow or stop your chair when it is moving. Doing so may cause a fall or tip-over.
2. To keep the rear wheels from rolling, always set both rear wheel locks when you transfer to or from your chair.
3. Low pressure in a rear tire may cause the wheel lock on that side to slip and may allow the wheel to turn when you do not expect it.
4. Make sure lock arms embed in tires at least 1/8 inch when locked. If you fail to do so, the locks may not work.

If you fail to heed these warnings damage to your chair, a fall, tip-over or loss of control may occur and cause severe injury to the rider or others.

L. MODIFIED SEAT SYSTEMS**⚠ WARNING**

Use of a seat system not approved by Sunrise may affect or interfere with other parts of the chair. This may cause the chair to tip over.

1. Do not change the seat system of your chair UNLESS you consult your authorized supplier first.
2. Use of a seating system not approved by Sunrise may affect the folding mechanism of this chair.
3. Use of a seating system not provided by Sunrise is prohibited for transit use.

If you fail to heed these warnings damage to your chair, a fall, tip-over or loss of control may occur and cause severe injury to the rider or others.

M. SEAT AND BACK UPHOLSTERY**⚠ WARNING**

1. Replace worn or torn fabric of seat and seat back as soon as you can. If you fail to do so, the seat or seat back may fail.
2. Sling fabric will weaken with age and use. Look for fraying, thin spots, or stretching of fabrics especially at edges and seams.
3. "Dropping down" into your chair will weaken fabric and result in the need to inspect and replace the seat more often.
4. Be aware that laundering or excess moisture will reduce the flame retardation qualities of the fabric.
5. If Tension Adjustable upholstery is present, loosen straps or remove upholstery prior to folding or unfolding the chair.

If you fail to heed these warnings damage to your chair, a fall, tip-over or loss of control may occur and cause severe injury to the rider or others.

N. POWER DRIVE**⚠ WARNING**

Do not install a power drive on any Zippie Wheelchair that has not been approved by Sunrise Medical.

1. It will affect the center of balance of your chair and may cause a fall or tip-over.
2. It will alter the frame and void the warranty.

If you fail to heed these warnings damage to your chair, a fall, tip-over or loss of control may occur and cause severe injury to the rider or others.

O. DYNAMIC BACKREST**⚠ WARNING**

Do not use any Dynamic Backrest setup other than what was provided by Sunrise Medical with your original chair.

1. It will affect the center of balance of your chair and may cause a fall or tip-over.
2. It will alter the frame and void the warranty.

If you fail to heed these warnings damage to your chair, a fall, tip-over or loss of control may occur and cause severe injury to the rider or others.

P. ANTI-TIP RECEIVERS**⚠ WARNING**

The Anti-tip receivers are designed to move with the axle location and are assembled in our manufacturing facilities.

1. Do not attempt to change the location of the Anti-tip receivers, or remove them UNLESS you consult your authorized supplier first.
2. Use of a Anti-tip system not approved by Sunrise may affect the center of gravity of the chair and lead to a fall or tip-over.

If you fail to heed these warnings damage to your chair, a fall, tip-over or loss of control may occur and cause severe injury to the rider or others.

⚠ WARNING

The owner of this chair is responsible for making sure that it has been set up and adjusted by a trained service professional under the advice of a healthcare advisor. The chair may require periodic safety checks or certain tool-free adjustments that may be performed by the owner, caregiver, or authorized dealer if desired. Always use parts and/or accessories that have been recommended or approved by Sunrise Medical when servicing this chair.

A. INTRODUCTION

1. Proper maintenance will improve performance and extend the useful life of your chair.
2. Clean your chair regularly. This will help you find loose or worn parts and make your chair easier to use. You will need a mild detergent solution and plenty of cleaning rags.
3. If discovered, repair or replace loose, worn, bent or damaged parts **before using the chair**. ALWAYS be sure to use Parts and/or accessories that have been recommended or approved by Sunrise Medical.
4. To protect your investment, have all major maintenance and repair work done by your authorized dealer.
5. Inspect and maintain this chair strictly per the Safety checklist.
6. If you detect a problem, make sure to order parts, or have service, and repair work done at your authorized dealer before use.
7. At least once per year, have a complete inspection, safety check, and service of your chair made by an authorized dealer.

B. CRITICAL SAFETY CHECKS

1. Tire Air Pressure:

Check air pressure in pneumatic tires at least **ONCE PER WEEK**. The wheel locks will not grip properly if you fail to maintain the air pressure shown on tire sidewall.

2. Axles & Axle Sleeves:

When checking axles and axle sleeves every six months, make sure they are clean and tight. Loose sleeves will damage the axle plate and will affect performance.

C. CLEANING TIPS

1. Paint Finish
 - a. Clean the painted surfaces with mild soap or detergent at least once a month.
 - b. Protect the paint with a coat of non-abrasive auto wax every three months.
2. Axles and Moving Parts
 - a. Clean around axles and moving parts WEEKLY with a slightly damp (not wet) cloth.
 - b. Wipe off or blow away any fluff, dust or dirt on axles or moving parts.
3. Upholstery
 - a. Hand-wash (machine washing may damage fabric).
 - b. Drip-dry only. DO NOT machine dry as heat will damage fabric.
4. Basic Maintenance Materials available at local store
 - a. Tire Pump
 - b. Tire Pressure Gauge
 - c. Clean rags or cotton cloth.
 - d. Teflon-based Lubricant
 - e. Mild Detergent.

NOTE- You do not need to grease or oil the chair.

D. SAFETY CHECKLIST

NOTE- The user or caregiver should perform these weekly and monthly checks to maintain the safety of their chair. If an item is not working properly, please contact your authorized dealer.

Weekly	3 Months	6 Months	Annually	Safety and Function Check...
<input checked="" type="checkbox"/>				Tire inflation level
<input checked="" type="checkbox"/>				Wheel locks
	<input checked="" type="checkbox"/>			Visually check for loose hardware
		<input checked="" type="checkbox"/>		Armrests
		<input checked="" type="checkbox"/>		Axle and axle sleeves
	<input checked="" type="checkbox"/>			Quick-release axles
	<input checked="" type="checkbox"/>			Wheels, tires and spokes
	<input checked="" type="checkbox"/>			Casters
	<input checked="" type="checkbox"/>			Anti-tip tubes
		<input checked="" type="checkbox"/>		Frame and crossbrace
	<input checked="" type="checkbox"/>			Upholstery
			<input checked="" type="checkbox"/>	Service by Authorized Supplier

E. TROUBLESHOOTING CHART

Symptom	Left turn in chair	Right Turn in chair	Looseness in chair	Sluggish turning	Squeaks and rattles	Caster flutter	Solution
							<input checked="" type="checkbox"/> <input checked="" type="checkbox"/> <input checked="" type="checkbox"/> <input checked="" type="checkbox"/> <input type="checkbox"/> <input type="checkbox"/>
<input type="checkbox"/> <input type="checkbox"/> <input checked="" type="checkbox"/> <input checked="" type="checkbox"/> <input checked="" type="checkbox"/> <input checked="" type="checkbox"/>	Make sure all nuts and bolts are tight.						
<input type="checkbox"/> <input type="checkbox"/> <input checked="" type="checkbox"/> <input type="checkbox"/> <input checked="" type="checkbox"/> <input type="checkbox"/>	Make sure all spokes and nipples are tight on radial spoke wheels.						
<input type="checkbox"/> <input type="checkbox"/> <input type="checkbox"/> <input type="checkbox"/> <input type="checkbox"/> <input checked="" type="checkbox"/>	Use Tri-Flow Lubricant (Teflon®-based) between frame connections and parts.						
<input checked="" type="checkbox"/> <input checked="" type="checkbox"/> <input type="checkbox"/> <input checked="" type="checkbox"/> <input type="checkbox"/> <input checked="" type="checkbox"/>	Check for proper caster fork adjustment. See instructions for caster fork adjustment.						

F. TO MOUNT & REMOVE REAR WHEELS 12 13**⚠ WARNING**

Do not use this chair UNLESS you are sure both quick-release axles are locked. An unlocked axle may come off during use and cause a fall.

1. To Install Wheel

- a. Depress quick-release button (A) fully. This will release tension on ball bearings at other end.
- b. Insert axle (B) through hub of rear wheel.
- c. Keep button (A) depressed as you slide axle (B) into axle sleeve (C).
- d. Release button to lock axle in axle sleeve. Adjust axle if it does not lock.
- e. Repeat steps on other side.

NOTE—The axle is not locked until the quick-release button pops out fully (A). Check that the axle is locked by pulling on the wheel in the direction of the axle.

2. To Remove Wheel

- a. Depress quick-release button (A) fully.
- b. Remove wheel by sliding axle (B) completely out of axle sleeve (C).
- c. Repeat steps on other side.

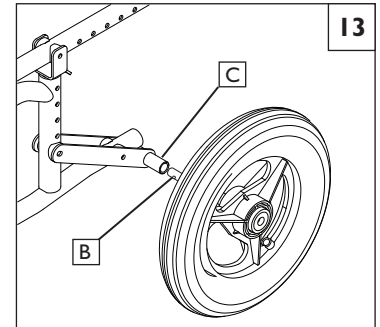
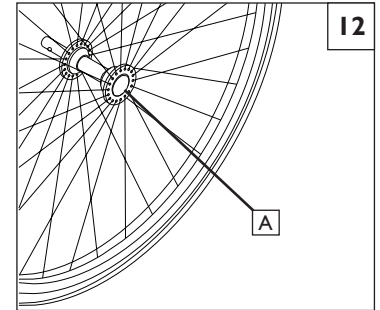
**G. WHEEL LOCKS** 14**⚠ WARNING**

Wheel locks are installed at Sunrise and should be adjusted by your qualified service person.

Inspect wheel locks weekly per the maintenance chart. Do not use your chair UNLESS you are sure both wheel-locks are fully engaged. A wheel-lock that is not correctly adjusted may allow your chair to roll, or turn unexpectedly.

Wheel-locks must be adjusted after making sure the tires have the correct air pressure. When fully engaged, the arm should be imbedded into the tire at least 1/8" (D) to be effective.

If you find the wheel locks have slipped or are not working correctly contact your service provider for proper adjustment.

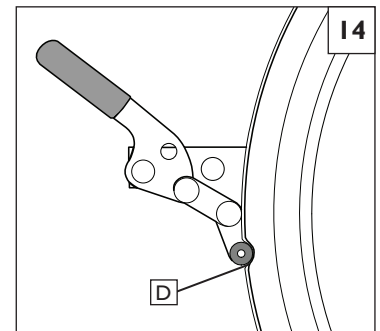
**H. HUB LOCKS** 15**⚠ WARNING****To operate Hub Lock**

1. To Lock rear wheels, press button (E). Lever (F) will flip outward.
2. To unlock wheels, press Lever (F) back down until Button (E) pops back out. Each lever operates one side of the chair. To fully lock chair, both buttons must be pushed.

NOTE - Do not engage hub lock when chair is in motion.

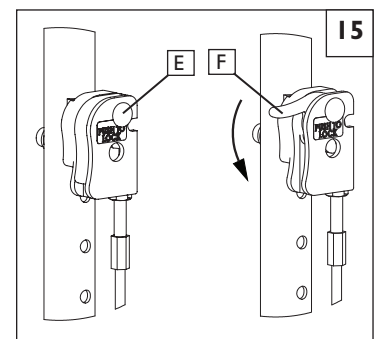

I. ANTI-TIPS 16 17 18

Sunrise Medical recommends anti-tip tubes for all wheelchairs.

1. Inserting Anti-Tip Tubes Into Receiver

- a. Press the rear anti-tip release pin (A) on the anti-tip tube so that both release pins are drawn inside.
- b. Insert into the anti-tip tube into the receiver (B).
- c. Turn the anti-tip tube down until release pin is positioned through the receiver mounting hole.
- d. Insert second anti-tip tube the same way.

2. Adjusting Anti-Tip Tube Wheel

The anti-tip tube wheels may have to be raised or lowered to achieve proper clearance 1 1/2" to 2".

- a. Press the anti-tip wheel release pin (F) so that the release pin is drawn inside.
- b. Raise or lower to one of the three predrilled holes.
- c. Release pin.
- d. Adjust the second anti-tip tube wheel the same way. Both wheels should be at exactly the same height.

3. Turning Anti-Tip Tubes Up

Turn anti-tip tubes up when being pushed by attendant, overcoming obstacles or climbing curbs.

- a. Press the rear anti-tip tube release pin.
- b. Hold pin in and turn anti-tip tube up.
- c. Release pin, and make sure the anti-tip is locked in place.
- d. Repeat these steps with second anti-tip tube.

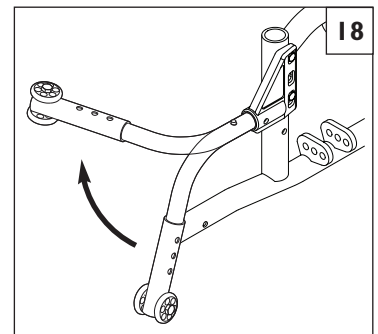
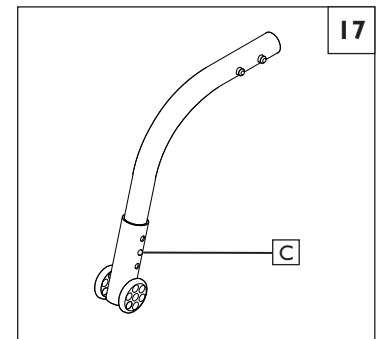
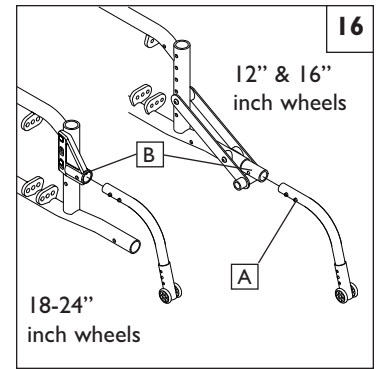

J. SINGLE POST HEIGHT ADJUSTABLE ARMREST 19

Sunrise medical offers several different types of armrests. Fixed, swing-away, and Flip-back armrests. Flip-back armrests can be detached or can flip back to allow lateral transfers. They are height adjustable (1" increments) by flipping the adjustment lever and moving the armrest pad (1) up or down to the desired height.

1. Basic Installation

- a. Slide the outer armpost (4) into the receiver mounted to the wheelchair frame.
- b. The armrest should lock into place.

2. Height Adjustment

- a. Release the upper securing lever (2).
- b. Slide armpad up or down to desired height.
- c. Return lever to locked position.

3. Removing Armrest

- a. To remove, grasp the unlocking lever (3) and pull up on the Armrest..

4. Replacing Armrest

- a. Slide armrest back into receiver.
- b. Make sure that the unlocking lever (3) returns to the locked position against armpost

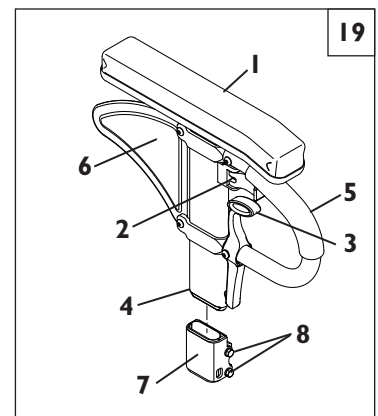

1. Armrest pad
2. Height Release Lever
3. Release lever
4. Outer armpost
5. Transfer bar
6. Side panel
7. Receiver
8. Receiver adjustment hardware

K. Z-FINITY™ FOOTREST SYSTEM (Option) 20 21

With the Z-finity footrest system, Sunrise Medical offers either a single Flip-up Footplate (A), or dual footplates (B) that are able to accommodate all of the possible heights and adjustment angles that the rider may require for their comfort and support.

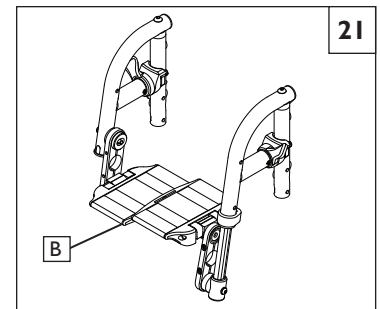
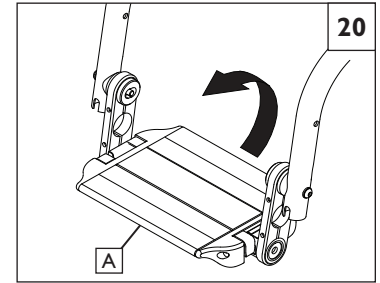

L. SWING IN/OUT HANGERS/FOOTRESTS 22

Exterior Mount (60°, 70°, 80°)

Front Mount (70°, 80°, 90°)

1. Installation

- a. Place swing-in/swing-out pivot saddle into the receiver (C) on front frame tube with the footrest facing inward or outward from the frame.
- b. Rotate the footrest inward until it locks into place on locking plate(D).

2. Removal

- a. To remove footrest, release latch (E) by pulling lever upward or pushing lever downward.
- b. Rotate footrest inward or outward and lift.

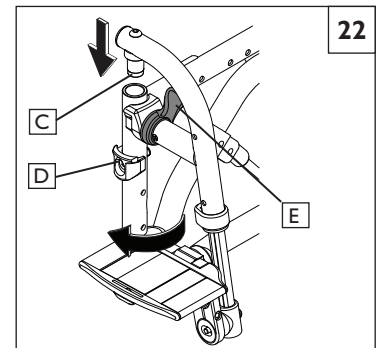

M. HEAVY-DUTY, LIFT-OFF FOOTRESTS (optional) 23

1. Installation

Slide pivot saddle (F) over receiver (G) on front frame tube until it locks into place.

2. Removal

To remove footrest, push release latch (H) while lifting up footrest from receiver.

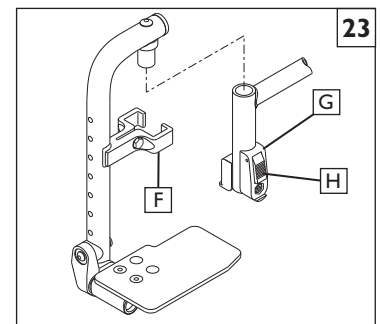

N. ARTICULATING / ELEVATING LEGREST (optional) 24

1. Installation or Removal

To install or remove Articulating Legrest (ALR) see instructions for Swing-away Footrest installation.

2. Elevation Adjustment

- a. To raise legrest, lift to desired position. Legrest will automatically lock in place.
- b. To lower legrest, while seated in chair, press release lever (I) down and lower Legrest to desired position. Legrest will automatically lock in place.

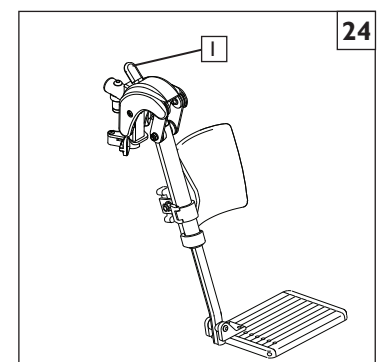

Articulating Legrest shown

O. FOLDING AND UNFOLDING 25

⚠ WARNING

Possible pinch point! BE CAREFUL.

NOTE– Only chairs with cross brace assembly will fold.

1. To fold the chair, remove the seat and back.
2. Pull the cross brace strap (A) up.
3. Press the side frames together firmly.
4. To open the chair, extend fingers and apply even pressure with palm of hand directly on cross brace until it is fully extended.
5. Replace the seat and back.
6. To avoid pinching, be careful when folding or unfolding a chair.

NOTE – Ensure that footrests are Flipped down, and locked prior to use.

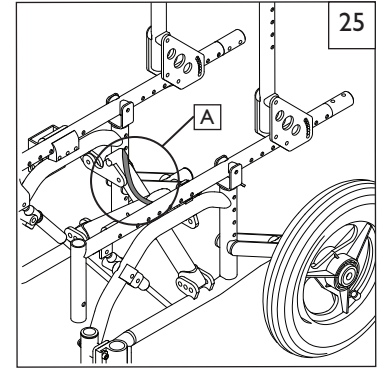

P. INTEGRATED STROLLER HANDLES 26

Positioning Swing-Away Adjustable Stroller Handles (option)

Loosen push handle (B) by pushing the Black button (C). You can then raise or lower Stroller handle to desired position.

NOTE - For easy storage and portability, push handles will swing in and stroller handles fold flat.

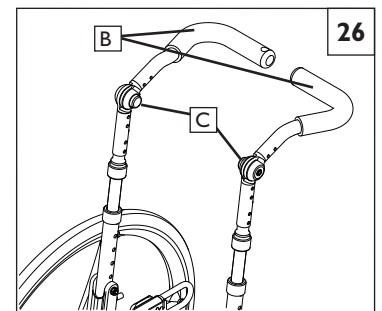

Q. BACKREST 27 28

NOTE– Zippie series wheelchairs are shipped with the backrest in a folded position.

1. Folding the backrest

- a. For easier storage and transport, Locate the backrest release pin lever (E) on both sides and pull up on the levers while pushing the backrest forward.

2. Unfolding the backrest

- a. To secure the back rest in a riding position, lift by the handles to an upright position. When secured, the backrest release pin will lock into place.

NOTE - For easy storage and portability, push handles should fold flat and not interfere with folding.

NOTE– Zippie series wheelchairs are shipped with the backrest in a folded position.

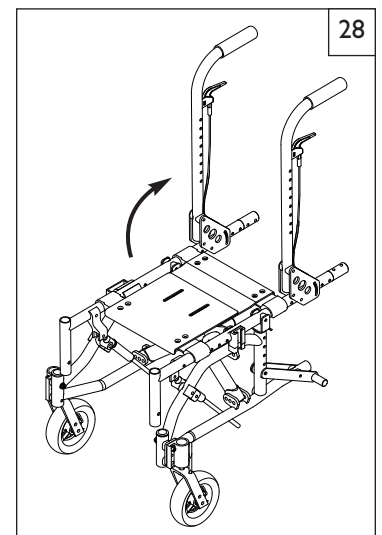
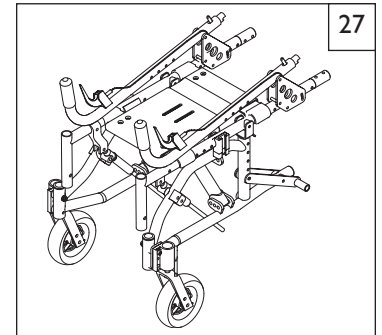

R. STORAGE TIPS

1. Store your chair in a clean, dry area. If you fail to do so, parts may rust or corrode.
2. Before using your chair, make sure it is in proper working order. Inspect and service all items on the "Maintenance Chart".
3. If stored for more than three months, have your chair inspected by an authorized supplier before use.

S. CHECK-OUT

After the wheelchair is assembled and adjusted, it should roll smoothly and easily. All accessories should also perform smoothly. If you have any problems, follow these procedures:

1. Review the set-up and check-out sections to make sure chair was properly prepared.
2. Review troubleshooting guide.
3. If your problem persists, contact your authorized supplier. If you still have a problem after contacting your authorized supplier, contact Sunrise customer service. See the introduction page for details on how to contact your authorized supplier or Sunrise customer service.

⚠ WARNING

The owner of this chair is responsible for making sure that it has been setup and adjusted by a trained service professional under the advice of a healthcare advisor. Service and/or adjustments should only be done with the advice of a healthcare professional. Always use parts and/or accessories that have been recommended and approved by Sunrise Medical when servicing this chair.

A. DEALER SERVICE INTRODUCTION

1. At least once per year, this chair should have a complete inspection, safety check, and regular service made by an authorized dealer.
2. Torque settings– A torque setting is the optimum tightening which should be made on a particular fastener. It is important to use proper torque settings where specified. When not specified, torque settings should be 60 in-lbs
3. If you have discovered a worn, bent, or damaged part, repair or replace them with recommended parts **before returning this chair to service.**
4. All major maintenance and repair work should be done by the authorized dealer.

B. CRITICAL MAINTENANCE TIPS

1. Torque settings:

A torque setting is the optimum tightening which should be made on a particular fastener. It is important to use proper torque settings where specified. When not specified, torque settings should be 60 in-lbs

2. Dealer Service and Adjustment Reference materials:

Go to www.sunrisemedical.com for parts manuals, instruction sheets, and instructional videos that will aid in the repair of the Zippie Family of wheelchairs.

C. CLEANING

1. Paint Finish

- a. Clean the painted surfaces with mild soap or detergent.
- b. Protect the paint with a coat of non-abrasive auto wax.

2. Axles and Moving Parts

- a. Clean around axles and moving parts with a slightly damp (not wet) cloth.
- b. Wipe off or blow away any fluff, dust or dirt on axles or moving parts.
- c. **DO NOT USE 3 in 1 oil, or WD-40 ® for lubrication. Only use Teflon based Lubricant when working on this wheelchair.**

D. REAR WHEEL ADJUSTMENT 30 31

1. Seat Height Adjustment

- a) Remove the rear wheel (See Quick-Release Axle).
- b) Remove the bolts (A) from the axle sleeve bracket (B).
- c) Raise or lower axle sleeve bracket to desired height.
- d) Additional seat height adjustment may be made by flipping axle sleeve bracket top to bottom (as shown) and exchanging them from side to side.
- e) Replace and tighten bolts. Replace wheel.

NOTE- Reversing the axle sleeve brackets from side to side may affect wheelbase width (see Wheelbase Width).

2. Wheelbase Width Adjustment

- a) Remove the rear wheel (See Quick-Release Axle).
- b) Remove the bolts from the axle sleeve bracket (A) on each side of the chair.
- c) Reverse the axle sleeves (B) with the wide side (B) facing away from the chair for increased width.
- d) Replace and tighten bolts. Replace wheel.

NOTE- To retain the same height, you must exchange the axle sleeve brackets from side to side.

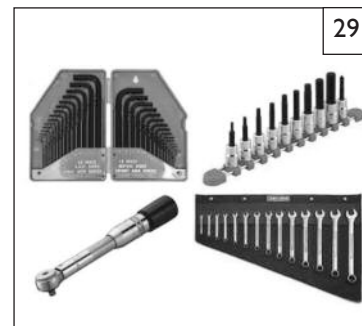

TOOLS YOU WILL NEED

1. Imperial Hex key set
2. Metric Hex key set
3. Imperial Open-end Wrench set
4. Metric Open-end Wrench set
5. Torque wrench
6. Imperial Hex bit Socket set
7. Metric Hex bit Socket set
8. Phillips and Flat screwdrivers

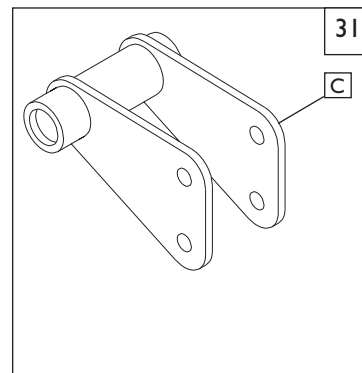
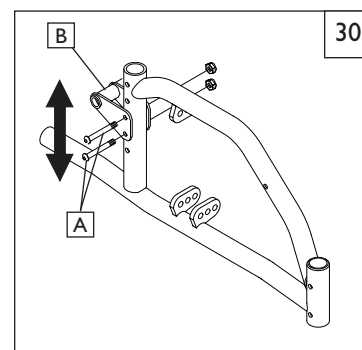

E. REAR WHEEL AXLE NUT ADJUSTMENT 32

Tight axle sleeves should be maintained for proper performance of the wheelchair.

- a. To adjust the axle (A) you will need a 3/4" wrench to turn the outside axle nuts (C).
- b. You will also need a 1/2" wrench to lodge the ball bearings (B), on the opposite end of the axle, and prevent the axle from turning.
- c. Turn the outside axle nut (D) clockwise to tighten.
- d. There should only be zero to ten thousandths of an inch (.010") of play.

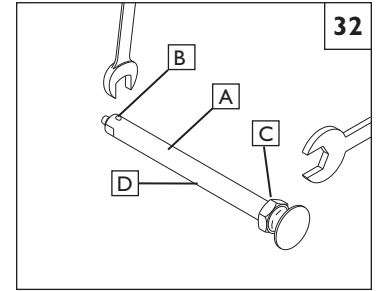

F. WHEEL LOCKS 33

1. High-Mount Wheel Lock

- a) Loosen the screws on the top of each clamp (E). Do not attempt to remove one screw at a time.
- b) Slide assembly toward rear wheel until clamp (F) embeds into tire to prevent wheel movement when in locked position.
- c) Adjust angle position.
- d) Tighten screws.

NOTE– Use a torque setting of 100 in.-lbs. when setting up wheel locks.

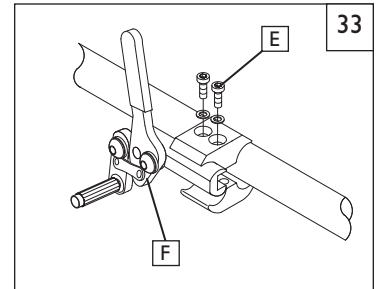

G. HUB LOCKS 34

1. To adjust the cables

1. Loosen jam nut (J) using a 10mm wrench.
2. Turn adjustment screw (G) in or out as necessary. Turning screw upward will loosen cable, turning downward will tighten cable.
3. Re-tighten jam nut (F) against lever mount.
4. Repeat steps 1-3 for opposite side of chair as necessary.

2. To adjust lever position

1. Remove socket screw (H) and washer (I) from lever and backrest.
2. Choose desired hole in backrest to mount lever and re-install screw and washer.
3. Repeat steps 1-2 for opposite side of chair

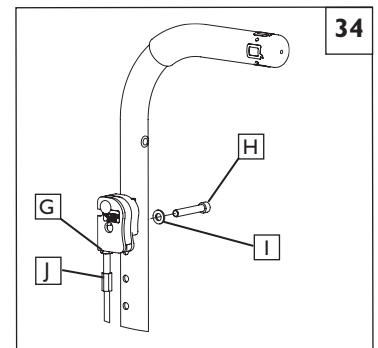

H. ANTI-TIP RECEIVER 35

NOTE – Rear anti-tip brackets are attached with axle plate hardware (see Seat Height Adjustment section).

1. To Adjust the Rear Anti-Tip Bracket Height

- a) Remove the two hex bolts (K).
- b) Raise or lower as needed.
- c) Replace and tighten bolts.

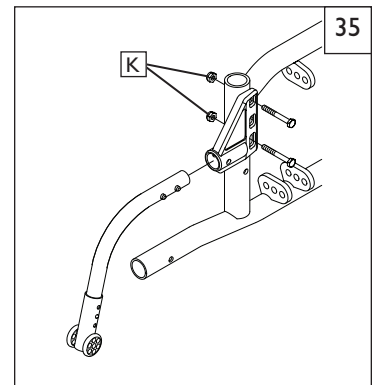

I. ARMREST RECEIVER ATTACHMENT 36

1. Mounting

1. Thread the two screws and washers (A) thru the rear side frame tube, and into the single post height-adjustable armrest receiver (B).
2. Tighten the hardware to 120 in-lbs.

2. Adjustment

1. To adjust the fit of the Single Post Armrest in the receiver, loosen the 4 hex bolts (C) by using a 7/16" wrench .
2. With the armrest assembly in the receiver (B), press firmly on the outside of the receiver.
3. Maintain pressure on the receiver and re-tighten two of the hex bolts (C).
4. Remove the armrest assembly and re-tighten the remaining two hex bolts.
5. The armrest should fit firmly into the receiver and lessen any noise that may result from vibration.

NOTE- Armrest Receiver may share hardware with wheel lock assembly if required.

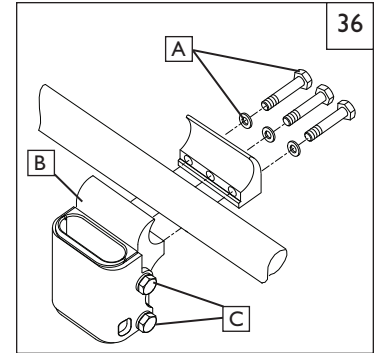

J. FLIP-UP ARMRESTS 37

Adjustment

Flip-up armrests are height adjustable (3") by moving the armrest assemblies up or down in the pre-drilled holes on the backrest frame tubes.

- a) To adjust armrest upward and downward, loosen cam adjustment bolt (D).
- b) Rotate armrest to desired position.
- c) Replace and tighten bolt.

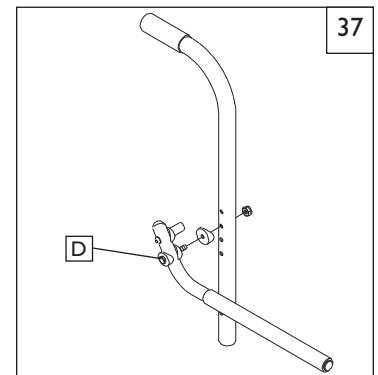

K. ADJUSTABLE LOCKING FLIP-UP ARMREST 38

1. Height Adjustment

- a) Remove the hex nuts from the armrest (E) and angle adjustment plate (F) to release the armrest and plate.
- b) Release the screws from the arm mount.
- c) Move mount up or down the back post in 1-inch increments for desired height, or within the arm mount holes for 1/4" inch increments.
- d) Replace and tighten nuts and bolts.

2. Angle Adjustment

- a) Loosen the hex nut from the angle adjustment plate (G).
- b) Tilt the armrest and plate to the desired angle.
- c) Tighten nut.

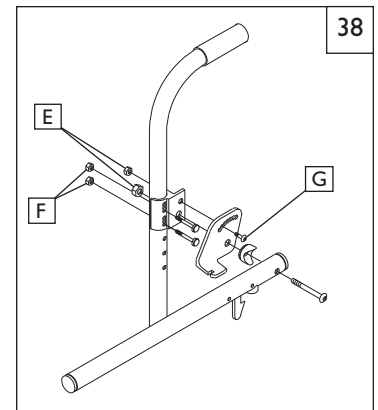

L. T-POST ARMREST 39

1. Lateral Adjustment

- a. Remove the receiver bolts (H).
- b. Move the Receiver (I) forward or back to the desired position.
- c. Tighten the hardware to 120 in-lbs

2. Height Adjustment

- a. Remove the screws for the Kids Arm Stop (J).
- b. Using one of the three preset holes in armrest post, adjust to the preferred height. .
- c. Replace and tighten hardware. to 120 in-lbs

NOTE - Armrest Receiver may share hardware with wheel lock assembly if required.

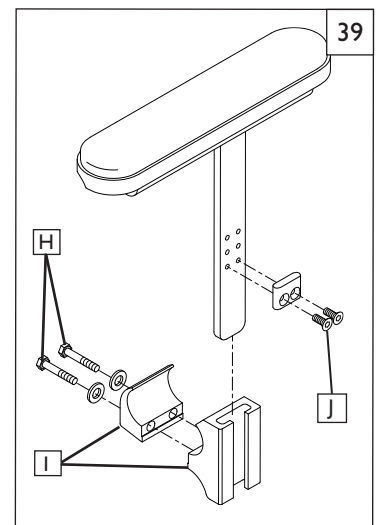

M. X-FINITY™ FOOTREST SYSTEM 40 41 42

The footrest position is key to keeping the body in the proper alignment, and providing a stable support for your legs and torso. Make sure that your Sunrise dealer has correctly adjusted your footrests and/or legrests with the advice of a healthcare professional. The original setup should not be changed without first checking with that advisor. Legrests and footrests should be swung out of the way, or removed for transfers. .

NOTE – Footplate must have at least 2inches of clearance between the footplate and the ground to prevent hitting obstacles and risking a fall or tip-over.

1. Footrest/Footplate positioning using the rotational clamp

- a. Loosen the two rotational/Angle clamp screws (A)
- b. Rotate the footrest/ footplate until the desired position and angle is achieved.
- c. Tighten the Clamp hardware to proper torque (DO NOT EXCEED a 120 in-lb Max torque).

2. Footrest positioning using footplate spacers

- a. Remove footplate spacers (B)
- b. Slide footplate to desired depth position.
- c. Replace footplate spacers

3. Height range adjustment (Direct Mount Footrest)

- a. Adjust the footplate mounting position by removing the button head screw from the adjustment hole (C) and moving the assembly to the desired position.
- b. Tighten hardware to proper torque (120 in-lb Max)

4. Height range adjustment (Extension Mount Footrest)

- a. Loosen set screw (D)
- b. Slide footrest extension tube up or down inside frame tube to desired height.
- c. Tighten set screw to proper torque (120 in-lb)

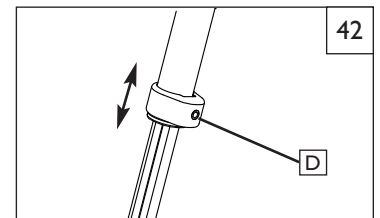
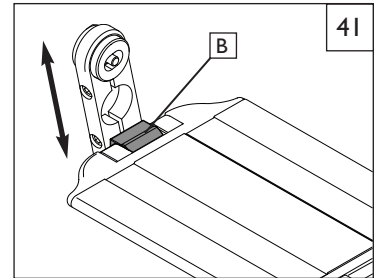
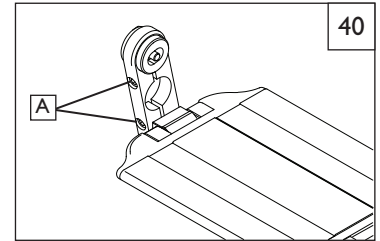

N. ARTICULATING LEGREST 44

1. Height Adjustment of the Calf Pad

- a. Loosen the retaining nut (E) located at the back of the calf pad bracket assembly.
- b. Slide the calf pad bracket assembly up or down.
- c. Tighten the retaining nut (E) once the pad is in the desired position.

2. Height Adjustment with Extension Tube

- a. (See “Swing-away Height Adjustment” Section)

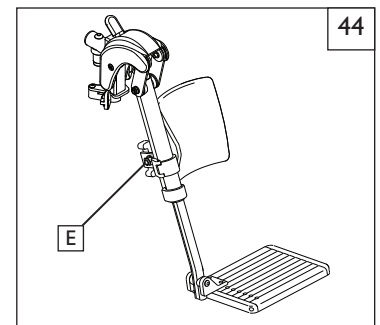

O. ELEVATING LEGREST 45

1. Height Adjustment of the Calf Pad

- a. Loosen the retaining nut (F) located at the back of the calf pad bracket assembly.
- b. Slide the calf pad bracket assembly up or down.
- c. Tighten the retaining nut (F) once the pad is in the desired position.

2. Height Adjustment with Extension Tube

- a. (See “Swing-away Height Adjustment” Section)

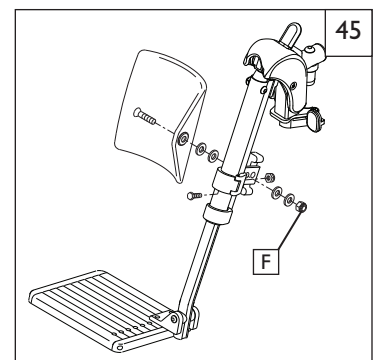

P. KIDS & ADULT ANGLE ADJUSTABLE FOOTPLATE 46 47

1. Height Adjustment

- a) Remove the retaining bolt from the frame tube (A).
- b) Move footplate assembly to desired height.
- c) Left and right footrest will normally be at equal height.
- d) Replace and tighten bolt.

2. Angle Adjustment

- a) Loosen fasteners (B) until the adjustable clamp and footplate rotate freely on the mounting tube.
- b) Adjust the angle of the footplate.
- c) Tighten nuts.

3. Position Adjustment

- a) Remove footplate fasteners (B).
- b) Move footplate to the desired location.
- c) Replace and tighten fasteners.

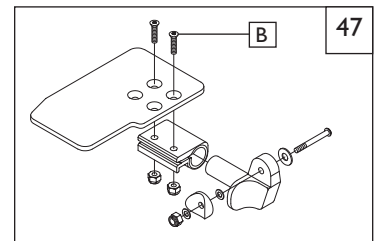
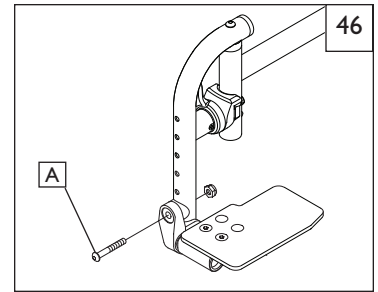

Q. ALUMINUM FOOTPLATE 48

1. Height Adjustment

- a) Remove set screws (C) from frame tube.
- b) Slide footplate to desired height.
- c) The adjustment on each side of the footrest will normally be of equal height.
- d) Replace and tighten set screws.

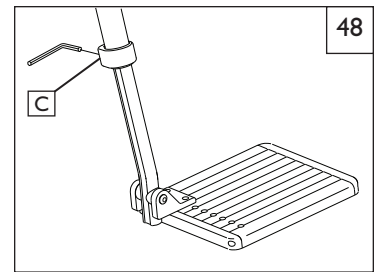

R. 90° FOOTBOARD 49

1. Height Adjustment

- a) Loosen the nuts on the footplate clamp assembly (D).
- b) Slide footplate clamps to desired height.
- c) Tighten nuts.

2. Angle Adjustment

- a) Loosen nuts under the footplate assembly (E) until the adjustable clamp rotates freely on the supporting tube.
- b) Adjust the angle of the footplate.
- c) Slide it forward or back for correct placement.
- d) Tighten nuts.

3. Removing Footboard

- a) Unscrew the lock knobs (F) and lift out of clamp assembly.

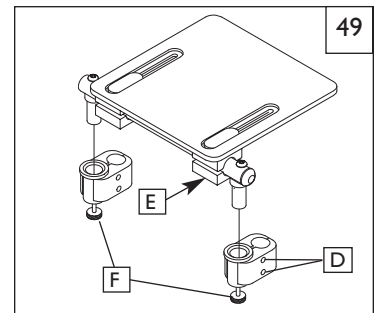

S. CASTER FORKS 50

1. Caster Fork Adjustment

- a) Loosen the bolt (G) and remove the caster.
- b) Either change caster size and/or position the caster upward or downward in pre-drilled holes (1" apart) on caster fork.
- c) Replace bolt and tighten securely.
- d) Repeat with other caster.

NOTE- Two-hole caster forks allow interchanging 5", 6" and 8" casters and adjusting seat height. These changes may affect the floor to seat height.

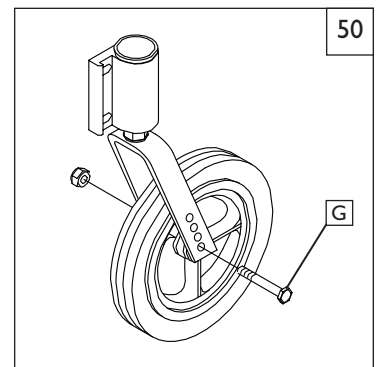

T. CASTER PLATES 51 52 53

1. Angle Adjustment

- Loosen the bolts (A) that secure the caster assembly until the eccentric washers are free to rotate.
- Place a large right triangle against a flat work surface and the front surface of the caster bearing housing. This will align the caster stem rotational axis perpendicular to the work surface.
- Align the eccentric washers and retighten the bolts.
- Repeat the process for the other caster.

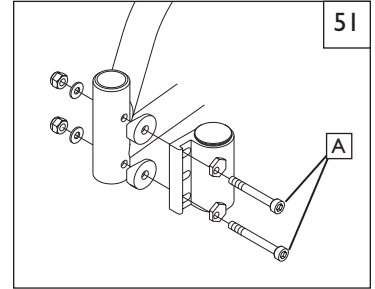

2. Angle Adjustment: Caster Plates with Transit Option

- Loosen the bolts (B) that secure the caster assembly.
- Place a large right triangle against the flat surface and the front surface of the caster bearing housing. This will align the caster stem rotational axis perpendicular to the flat surface.
- Align the eccentric washers and retighten the bolts.
- Repeat the process for the other caster.

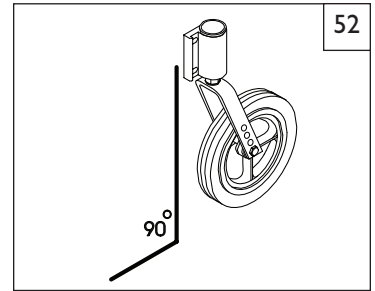

U. SEAT DEPTH 54 55

1. Pivot Plate Adjustment

- Remove the bolts (C) securing the back rest pivot plate (D) onto the tilt seat tube.
- Position the backrest pivot plate in the desired pre-drilled holes on the tilt seat tube. (See matrix below.)
- Replace bolts and tighten securely.

NOTE – A rear frame extension is available for 19" and 20" frame depths from your authorized Sunrise supplier.

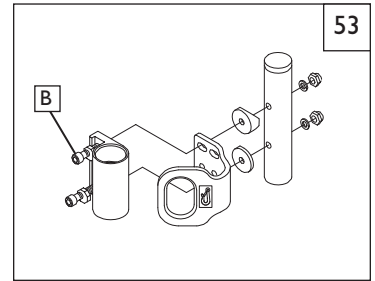

2. Tilt-in-Space Tube Adjustment

- Remove the bolts (E) from the tilt brackets and strut saddles.
- Move the tilt seat tube (F) to position the proper frame holes according to the matrix below for the tilt bracket.
- Replace and tighten bolts.

NOTE – Adjusting the position of the tilt seat tube will affect the chair's center of gravity and may require you to adjust the casters to a trailing or forward position.

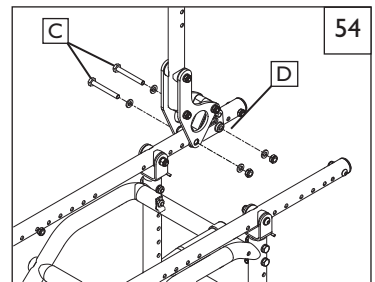
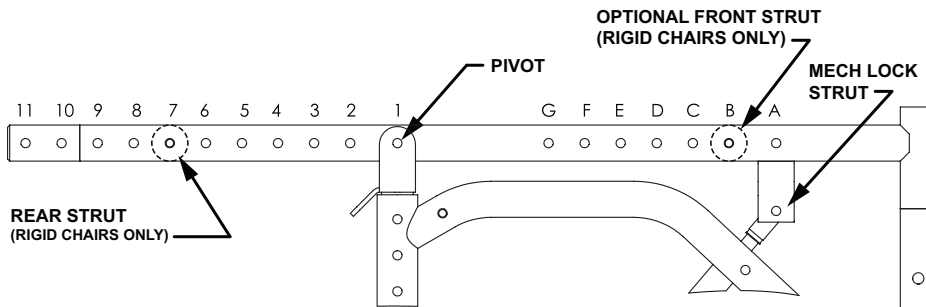

FRAME DEPTH	SEAT DEPTH	BACK PLATE POSITION	PIVOT POSITION	MECHLOCK STRUT POSITION	REAR STRUT TUBE POSITION	FRONT STRUT TUBE POSITION
13	11	2 & 4	1	A	6	B
14	12	3 & 5	1	A	7	B
15	13	4 & 6	2	B	8	A
16	14	5 & 7	2	B	9	A
17	15	6 & 8	3	C	9	A
18	16	7 & 9	3	C	5	A
19	17	8 & 10	4	D	11	A
20	18	9 & 11	4	D	7	A

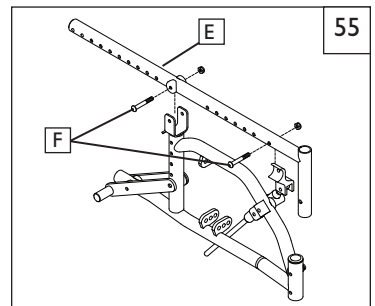

V. SOLID BACK AND SEAT INSERT 56

1. Attaching/Removal

- a) Position seat and back on the frame.
- b) Position clamps on the seat base and backposts.
- c) Insert the quick-release pins (A) through the mounting holes on both the base and backposts.
- d) Remove the seat by reversing the above process.

NOTE- May be equipped with Jay Fit or Conventional seating (see instructions from seating Owner's Manual).

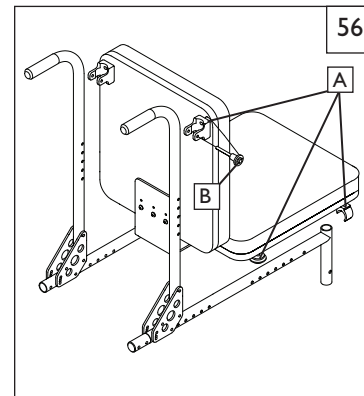

W. TILT-IN-SPACE 57 58 59

1. Tilt Adjustment

- a) Remove trigger release pin (C).
- b) Depress the lock lever handle (D), position to desired tilt, and release handle.
- c) Replace trigger release pin

2. Tilt-in-Space Mechanism Adjustment

- a) Rotate the jam nut (E) clockwise.
- b) Turn the cable adjuster piece (F) until looseness is removed from cable.
- c) Tighten jam nut.

NOTE – Adjustments to tilt-in-space mechanism are recommended to be made by authorized Sunrise suppliers.

3. Foot Release

Depressing foot pedal (G) disengages the locking mechanism and allows the seat and back to rotate in space. Releasing the foot pedal positively locks the rockers in place.

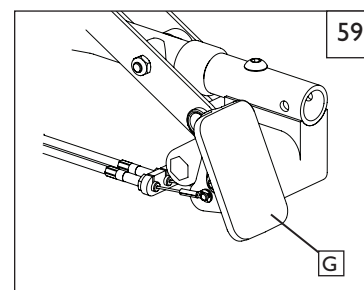
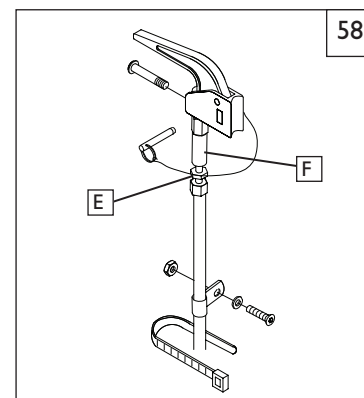
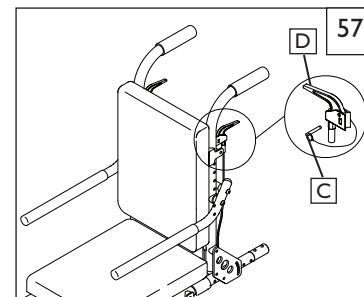

X. CABLE ADJUSTMENT 60

1. Loosen jam nut (A) from adapter (B) using 10mm wrench.
2. Using a 3/8" wrench, turn adapter clockwise as shown to remove slop in cable. If the seat is not holding the tilt angle securely, the cables may be adjusted too tight, and the adapter will need to be turned counter-clockwise.
3. Once proper adjustment is obtained, re-tighten jam nut against adapter.
4. Repeat for opposite side of chair as necessary.

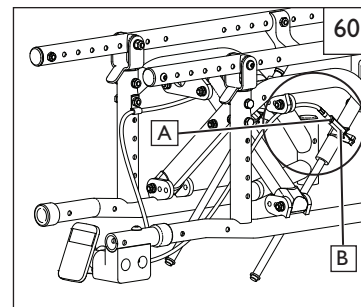

Y. CROSS BRACE 61

Adjustment

1. Remove the four bolts (A) that attach the cross brace to the side frames.
2. Move the cross brace to the desired location on the tabs (B).
3. Replace and tighten the bolts.

NOTE- Align the bolts through holes in the tabs that correspond on each side. Re-tighten bolts to 100 in.-lbs. Cross braces have 2" of width growth.

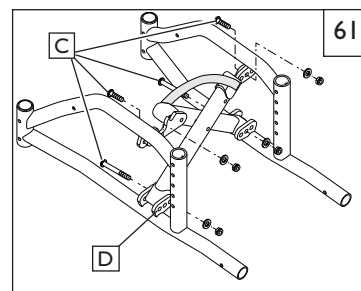

Z. STRUT TUBE ASSEMBLY 62

NOTE- Strut Tubes are installed on rigid chairs.

Width Adjustment

1. Remove hardware (E) from all strut tubes.
2. Slide the adjustable extension (F) to the desired width.
3. Replace and tighten the saddle bolts in the strut tubes.

NOTE- Strut tubes have 2" width adjustment available. Size changes may require a larger seat insert and footplates. Call your authorized Sunrise supplier for details. Use a torque setting of 100 in.-lbs. when making this adjustment.

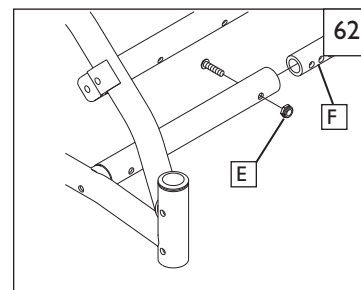

AA. GROWING SEAT PAN (optional) 63 64**1. Removing and Attaching the Seat Pan**

- To remove, grasp front of seat pan and firmly pull upward until seat mounting clips (A) disengage from the frame.
- To reattach, position seat pan on frame rail as desired and push down firmly on seat pan where it is attached to the seat mounting clips. Be sure to engage all four clips on frame rails.

NOTE– Rear of seat pan will be labeled.

⚠ WARNING

Check for engagement by pulling up lightly on seat pan. It should not move upward. Failure to check for engagement may lead to injury if the seat mounting clips are not fully seated.

2. Adjusting Seat Pan Width

- Remove the hardware (B) that secure each seat mounting clips (A) to the seat pan.
- Position the seat mounting clips to the desired position, reattach the screws. Each hole is .5" apart for a total of 2" of width adjustment range.

NOTE– Tighten screws to 100 in.lbs. torque.

- Repeat steps "a" and "b" for each mounting clip.

NOTE– Both sides must be mounted to same hole position.

3. Adjusting Seat Pan Depth

- Loosen the two lock nuts (C) on under side of seat pan that attach the front seat pan panel to rear seat pan panel.
- Reposition seat pan to the desired length, and reattach the lock nuts.

NOTE– Tighten lock nuts to 100 in. lbs. torque.

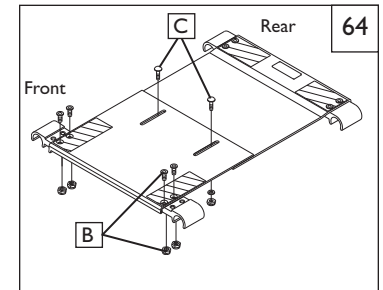
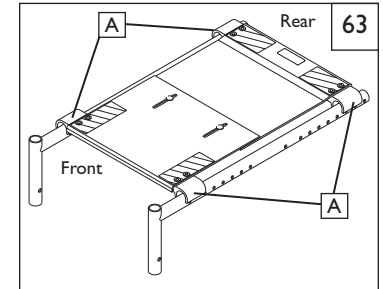
**BB. CHECK-OUT**

After the wheelchair is assembled and adjusted, it should roll smoothly and easily. All accessories should also perform smoothly. If you have any problems, follow these procedures:

- Review the set-up and check-out sections to make sure chair was properly prepared.
- Review troubleshooting guide.
- If your problem persists, contact Sunrise customer service. See the introduction page for details on how to contact Sunrise customer service.

A. FOR LIFETIME

Frame and cross-brace (if applicable) warranty:

1. Although the anticipated useful service time of this wheelchair is five years, Sunrise guarantees the frame and cross brace against defects in material and workmanship for life or for as long as the original purchaser owns the chair.
2. This warranty does not apply if:
 - a. The chair is subject to abuse
 - b. The chair is not maintained as recommended in the owner's manual
3. The chair is transferred to a different person from the original owner

B. FOR ONE (1) YEAR

We warrant all Sunrise-made parts and components of this wheelchair against defects in materials and workmanship for one year from the date of first consumer purchase.

Backrest Tension Adjustable (Ballistic & 3DX Vented)

Each Backrest Tension Adjustable is carefully inspected and tested to provide peak performance. Every Backrest Tension Adjustable is guaranteed to be free from defects in materials and workmanship for a period of twelve (12) months from the date of purchase provided normal use. Should a defect in materials or workmanship occur within twelve months from the original date of purchase, Sunrise Medical will, at its option, repair or replace it without charge. This warranty does not apply to puncture, tears or burns. Claims and repairs should be processed through the nearest authorized supplier. Except for express warranties made herein, all other warranties including implied warranties of merchantability and warranties of fitness for particular purpose are excluded. There are not warranties which extend beyond the description of the face hereof. Remedies for breach of express warranties herein are limited to repair or replacement of the goods. In no event shall damages for breach of any warranty include any consequential damages or exceed the cost of non-conforming goods sold.

C. LIMITATIONS

1. We do not warrant:
 - a. Tires and tubes, upholstery, pads and push-handle grips.
 - b. Damage from neglect, accident, misuse, or from improper installation or repair.
 - c. Products modified without Sunrise Medical's express written consent.
 - d. Damage from exceeding the weight limit.

2. This warranty is VOID if the original chair serial number tag is removed or altered.
3. This warranty applies in the USA and CANADA only. Check with your supplier to find out if international warranties apply.
4. This warranty is not transferable and only applies to the first consumer purchase of this wheelchair through an authorized Sunrise Medical dealer.

D. WHAT WE WILL DO

Our sole liability is to repair or replace covered parts. This is the exclusive remedy for consequential damages.

E. WHAT YOU MUST DO

1. Obtain from an authorized supplier, while this warranty is in effect, prior approval for return or repair of covered parts.
2. Return the wheelchair or part(s), freight pre-paid, to Sunrise Medical at: 2842 Business Park Avenue, Fresno, CA 93727-1328.
3. Pay the cost of labor to repair, remove or install parts.

F. NOTICE TO CONSUMER

1. If allowed by law, this warranty is in place of any other warranty (written or oral, express or implied, including a warranty of merchantability, or fitness for a particular purpose).
2. This warranty gives you certain legal rights. You may also have other rights that vary from state to state.

G. ADDITIONAL WARRANTY INFORMATION

For goods provided by Sunrise Medical Pty Ltd in Australia, our goods come with a guarantee by Sunrise that cannot be excluded under the Australian Consumer Law. You are entitled to a replacement or refund for a major failure and for compensation for any other reasonably foreseeable loss or damage. You are also entitled to have the goods repaired or replaced if the goods fail to be of acceptable quality and the failure does not amount to a major failure. The benefits to you given by this warranty are in addition to your other rights and remedies under a law in relation to the goods to which the warranty relates.

Record your serial number here for future reference:

Sunrise Medical (US) LLC

2842 Business Park Ave.
Fresno, CA 93727
USA
(800) 333-4000
www.sunrisemedical.com

Sunrise Medical, Inc.

237 Romina Drive, Unit 3
Concorde, Ontario L4K 4V3
CANADA
(800) 263-3390
www.sunrisemedical.ca

Sunrise Medical Limited

Thorns Road, Brierley Hill,
West Midlands,
DY5 2LD, England
Phone: 0845 605 66 88
Fax: 0845 605 66 89
www.sunrisemedical.com

Sunrise Medical GmbH+Co.KG

Kahlbachring 2-4
D-69254 Malsch/Heidelberg
DEUTSCHLAND
Tel.: +49 (0) 72 53/980-0
Fax: +49 (0) 72 53/980-111
www.sunrisemedical.com

Sunrise Medical S.L.

Polígono Bakiola, 41
48498 Arrankudiaga – Vizcaya
ESPAÑA
Tel.: +34 (0) 9 0214 24 34
Fax: +34 (0) 9 46 481575
www.sunrisemedical.es

Sunrise Medical S.A.

ZAC de la Vrillonnerie
17 Rue de Michaël Faraday
37170 Chambray Lès Tours
FRANCE
Tel.: +33 (0) 247 55 44 00
Fax: +33 (0) 247 55 44 03
www.sunrisemedical.com

Sunrise Medical Srl

Via Riva 20, Montale
29122 Piacenza (PC)
ITALY
Tel.: +39 (0) 05 23-57 3111
Fax: +39 (0) 05 23-570 60
www.sunrisemedical.it

Sunrise Medical A.G.

Lückhalde 14
3074 Muri bei Bern
SCHWEIZ
Tel.: +41 (0) 31-958-38 38
Fax: +41 (0) 31-958-38 48
www.sunrisemedical.ch

Sunrise Medical AS

Dynamitveien 14 B, 1400 Ski
T: 66 96 38 00
Faks: 66 96 38 80
E: post@sunrisemedical.no
www.sunrisemedical.no

Sunrise Medical AB

Box 9232
400 95 Göteborg
Besöksadress: Britta
Sahlgrenska 8A, Västra Frölunda
SWEDEN
Tel: +46 (0) 31-748 37 00
Fax: +46 (0) 31-748 37 37
www.sunrisemedical.se

Sunrise Medical B.V.

Groninghaven 18-20
3433 PE Nieuwegein
The NETHERLANDS
Tel.: +31 (0)30 – 60 82 100
E: info@sunrisemedical.nl
www.sunrisemedical.com

Sunrise Medical Australia Pty Ltd.

6 Healey Circuit, Huntingwood NSW 2148
Phone: (02) 9678 6600
Email: enquiries@sunrisemedical.com.au

Sunrise Medical QLD

15 Leda Drive, Burleigh Heads QLD 4220
Phone: (07) 5576 0888
Email: enquiries@sunrisemedical.com.au



This product is manufactured to comply with the 'Medical Device Directive' 93/42/EEC.

Questo prodotto è stato fabbricato in conformità alla direttiva 93/42/CEE relativa ai dispositivi medici.

Denna produkt har tillverkats i enlighet med EU:s direktiv om medicintekniska produkter nummer 93/42/EEC.

Dieses Produkt ist in Konformität mit der 'Richtlinie für Medizinprodukte' 93/42/EEC hergestellt.